



PH42-020-S300-R

Specifications

Item	Specifications
MCU	ARM CORTEX-M4 (168 [MHz], 32Bit)
Motor	Coreless (Maxon)
Baud Rate	9,600 [bps] ~ 10.5 [Mbps]
Operating Modes	Torque Control Mode Velocity Control Mode Position Control Mode Extended Position Control Mode PWM Control Mode(Voltage Control Mode)
Weight	340 [g]
Dimensions (W x H x D)	42 x 84 x 42 [mm]
Resolution	607,500 [pulse/rev]
Gear Ratio	303.75:1
Backlash	< 6 [arcmin], 0.1 [°]
Radial Load	280 [N] (10 [mm] away from the horn)
Axial Load	100 [N]
No Load Speed	32.7 [rev/min]

Item	Specifications
No Load Current	0.57 [A]
1 Continuous Speed	29.2 [rev/min]
1 Continuous Torque	5.1 [Nm]
1 Continuous Current	1.5 [A]
Output	20 [W]
Operating Temperature	-5 ~ 55 [° C]
Input Voltage	24.0 [V]
Command Signal	Digital Packet
Protocol Type	RS485 Asynchronous Serial Communication (8bit, 1stop, No Parity)
Physical Connection	RS485 Multidrop Bus
ID	253 ID (0 ~ 252)
Standby Current	30 [mA]

1 These specifications are calculated based on the specifications of the core motor.
Please consult ROBOTIS for the long term use or special use, or else refer to the Performance Graph for general use.

**DANGER**

(May cause serious injury or death)

Never place items containing water, flammables, and solvents near product.

Never place fingers, arms, toes, and other body parts near product during operation.

Cut power off if product emits strange odors or smoke.

Keep product out of reach of children.

Check the power polarity before wiring.

**CAUTION**

(May cause injury or damage to product)

Do not operate the product at a temperature exceeding -5 ~ 55 [° C] range.

Do not insert sharp blades nor pins during product operation.

**ATTENTION**

地址：北京市亦庄经济开发区凉水河二街8号大族企业湾7号楼A座2层 邮编：100176

网址：www.bjrobot.com 邮箱：znj@bjrobot.com 全国服务热线：400 099 1872

(May cause injury or damage to product)
 Do not disassemble or modify product.
 Do not drop or apply strong shock to product.
 Performance Graph

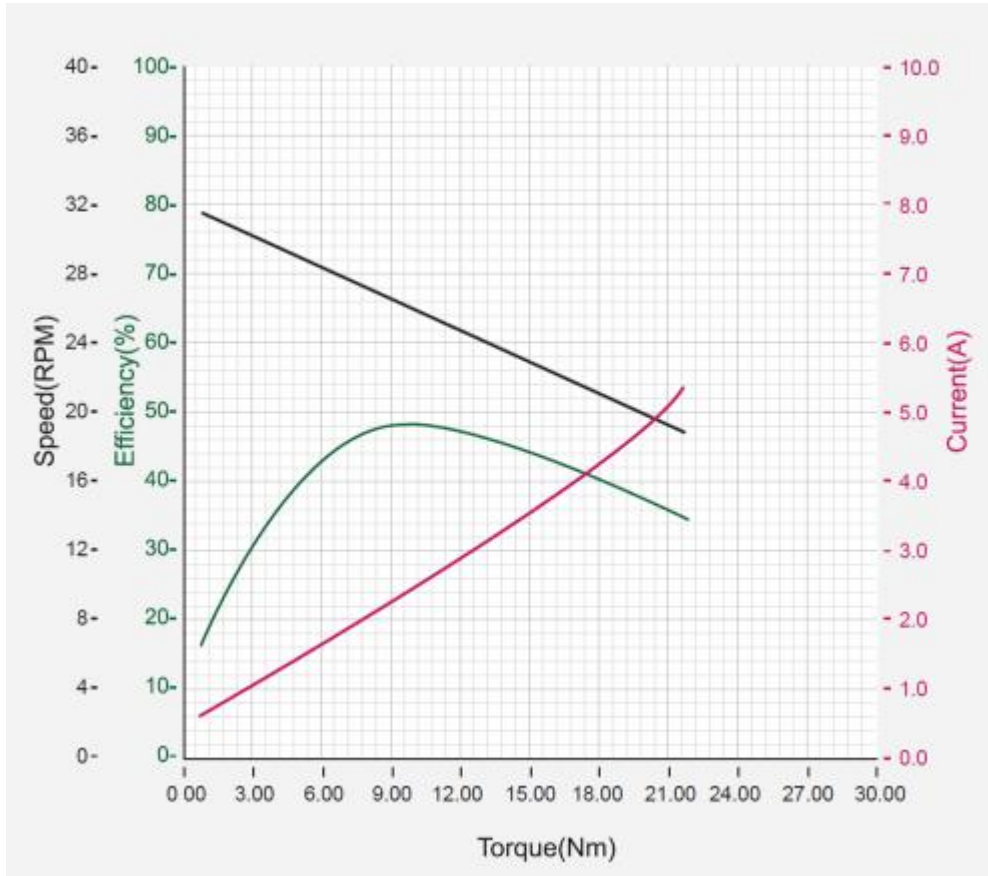

Show Enlarged Graph

NOTE : The Max Torque and the Stall Torque of Performance Graph are different in measurement methods. Stall torque is a measured value of the momentary torque that it can reach. This is generally how RC servos are measured. The Performance graph is also called as N-T curves, which is measured with the gradually increasing load. The actual motor operation environment is closer to the performance graph, not stall torque method. For this reason, the performance graph is broadly used in the industrial field. Generally, Max Torque of the Performance Graph is less than the Stall Torque.

CAUTION : When supplying power

It is recommended using ROBOTIS controller or SMPS2DYNAMIXEL.

Do not connect or disconnect DYNAMIXEL when power is being supplied.

In case of DYNAMIXEL PRO and DYNAMIXEL-P series, please supply power through 24V power port.

Control Table

The Control Table is a structure of data implemented in the device. Users can read a specific Data to get status of the device with Read Instruction Packets, and modify Data as well to control the

device with WRITE Instruction Packets.

WARNING : DYNAMIXEL-P series use different Control Table from DYNAMIXEL PRO series. Please pay attention when replacing DYNAMIXEL PRO with DYNAMIXEL-P series.

Control Table, Data, Address

The Control Table is a structure that consists of multiple Data fields to store status or to control the device. Users can check current status of the device by reading a specific Data from the Control Table with Read Instruction Packets. WRITE Instruction Packets enable users to control the device by changing specific Data in the Control Table. The Address is a unique value when accessing a specific Data in the Control Table with Instruction Packets. In order to read or write data, users must designate a specific Address in the Instruction Packet. Please refer to Protocol 2.0 for more details about Instruction Packets.

NOTE : Two's complement is applied for the negative value. For more information, please refer to Two's complement from Wikipedia.

Area (EEPROM, RAM)

The Control Table is divided into 2 Areas. Data in the RAM Area is reset to initial values when the power is reset(Volatile). On the other hand, data in the EEPROM Area is maintained even when the device is powered off(Non-Volatile).

Data in the EEPROM Area can only be written to if Torque Enable(512) is cleared to '0' (Off).

Size

The Size of data varies from 1 ~ 4 bytes depend on their usage. Please check the size of data when updating the data with an Instruction Packet. For data larger than 2 bytes will be saved according to Little Endian.

Access

The Control Table has two different access properties. 'RW' property stands for read and write access permission while 'R' stands for read only access permission. Data with the read only property cannot be changed by the WRITE Instruction. Read only property('R') is generally used for measuring and monitoring purpose, and read write property('RW') is used for controlling device.

Initial Value

Each data in the Control Table is restored to initial values when the device is turned on. Default values in the EEPROM area are initial values of the device (factory default settings). If any values in the EEPROM area are modified by a user, modified values will be restored as initial values when the device is turned on. Initial Values in the RAM area are restored when the device is turned on.

Control Table of EEPROM Area

Address	Size (Byte)	Modbus Address	Data Name	Access	Initial Value	Range	Unit
0	2	40001	Model Number	R	2,000	-	-
2	4	40002	Model Information	R	-	-	-
6	1	40004 (Lo)	Firmware Version	R	-	-	-

Address	Size (Byte)	Modbus Address (Byte)	Data Name	Access	Initial Value	Range	Unit
7	1	40004 (Hi Byte)	ID	RW	1	0 ~ 252	-
8	1	40005 (Lo Byte)	Baud Rate	RW	1	0 ~ 9	-
9	1	N/A	Return Delay Time	RW	250	0 ~ 254	2 [μ sec]
10	1	40006 (Lo Byte)	Drive Mode	RW	0	0 ~ 1	-
11	1	40006 (Hi Byte)	Operating Mode	RW	3	0, 1, 3, 4, 16	-
12	1	N/A	Secondary(Shadow) ID	RW	255	0 ~ 255	-
13	1	40007 (Hi Byte)	Protocol Type	RW	2	2, 10	-
20	4	40011	Homing Offset	RW	0	-2,147,483,648 ~ 2,147,483,647	1 [pulse]
24	4	40013	Moving Threshold	RW	20	0 ~ 2,920	0.01 [rev/min]
31	1	40016 (Hi Byte)	Temperature Limit	RW	80	0 ~ 100	1 [° C]
32	2	40017	Max Voltage Limit	RW	350	150 ~ 350	0.1 [V]
34	2	40018	Min Voltage Limit	RW	150	150 ~ 350	0.1 [V]
36	2	40019	PWM Limit	RW	2,009	0 ~ 2,009	-

Address	Size (Byte)	Modbus Address	Data Name	Access	Initial Value	Range	Unit
38	2	40020	Current Limit	RW	4,500	0 ~ 4,500	1 [mA]
40	4	40021	Acceleration Limit	RW	10,765	0 ~ 4,306,173	1 [rev/min ²]
44	4	40023	Velocity Limit	RW	2,920	0 ~ 2,920	0.01 [rev/min]
48	4	40025	Max Position Limit	RW	303,454	-303,750 ~ 303,750	1 [pulse]
52	4	40027	Min Position Limit	RW	-303,454	-303,750 ~ 303,750	1 [pulse]
56	1	40029 (Lo Byte)	External Port Mode 1	RW	3	0 ~ 3	-
57	1	40029 (Hi Byte)	External Port Mode 2	RW	3	0 ~ 3	-
58	1	40030 (Lo Byte)	External Port Mode 3	RW	3	0 ~ 3	-
59	1	40030 (Hi Byte)	External Port Mode 4	RW	3	0 ~ 3	-
63	1	40032 (Hi Byte)	Shutdown	RW	58	0 ~ 255	-
168	2	N/A	Indirect Address 1	RW	634	512 ~ 1,023	-
170	2	N/A	Indirect Address 2	RW	635	512 ~ 1,023	-
172	2	N/A	Indirect Address 3	RW	636	512 ~ 1,023	-
...
422	2	N/A	Indirect Address 128	RW	761	512 ~ 1,023	-

Control Table of RAM Area

Address	Size (Byte)	Modbus Address	Data Name	Access	Initial Value	Range	Unit
512	1	40257 (Lo Byte)	Torque Enable	RW	0	0 ~ 1	-
513	1	40257 (Hi Byte)	LED Red	RW	0	0 ~ 255	-
514	1	40258 (Lo Byte)	LED Green	RW	0	0 ~ 255	-
515	1	40258 (Hi Byte)	LED Blue	RW	0	0 ~ 255	-
516	1	N/A	Status Return Level	RW	2	0 ~ 2	-
517	1	N/A	Registered Instruction	R	0	-	-
518	1	40260 (Lo Byte)	Hardware Error Status	R	0	-	-
524	2	40263	Velocity I Gain	RW	-	0 ~ 32,767	-
526	2	40264	Velocity Gain P	RW	-	0 ~ 32,767	-
528	2	40265	Position Gain D	RW	-	0 ~ 32,767	-
530	2	40266	Position I Gain	RW	-	0 ~ 32,767	-
532	2	40267	Position Gain P	RW	-	0 ~ 32,767	-
536	2	40269	Feedforward 2nd Gain	RW	-	0 ~ 32,767	-
538	2	40270	Feedforward 1st Gain	RW	-	0 ~ 32,767	-
546	1	40274 (Lo Byte)	Bus Watchdog	RW	-	0 ~ 127	20 [msec]
548	2	40275	Goal PWM	RW	-	-PWM Limit(36) ~	-

Address	Size (Byte)	Modbus Address	Data Name	Access	Initial Value	Range	Unit
						PWM Limit(36)	
550	2	40276	Goal Current	RW	-	-Current Limit(38) ~ Current Limit(38)	1 [mA]
552	4	40277	Goal Velocity	RW	-	-Velocity Limit(44) ~ Velocity Limit(44)	0.01 [rev/min]
556	4	40279	Profile Acceleration	RW	-	0 ~ Acceleration Limit(40)	1 [rev/min ²]
560	4	40281	Profile Velocity	RW	-	0 ~ Velocity Limit(44)	0.01 [rev/min]
564	4	40283	Goal Position	RW	-	Min Position Limit(52) ~ Max Position Limit(48)	1[pulse]
568	2	40285	Realtime Tick	R	-	0 ~ 32,767	1 [msec]
570	1	40286 (Lo Byte)	Moving	R	-	-	-
571	1	40286 (Hi Byte)	Moving Status	R	-	-	-
572	2	40287	Present PWM	R	-	-	-
574	2	40288	Present Current	R	-	-	1 [mA]
576	4	40289	Present Velocity	R	-	-	0.01 [rev/min]
580	4	40291	Present Position	R	-	-	1 [pulse]

Address	Size (Byte)	Modbus Address	Data Name	Access	Initial Value	Range	Unit
584	4	40293	Velocity Trajectory	R	-	-	0.01 [rev/min]
588	4	40295	Position Trajectory	R	-	-	1 [pulse]
592	2	40297	Present Input Voltage	R	-	-	0.1 [V]
594	1	40298 (Lo Byte)	Present Temperature	R	-	-	1 [° C]
600	2	40301	External Port Data 1	R/RW	0	0 ~ 4,095	-
602	2	40302	External Port Data 2	R/RW	0	0 ~ 4,095	-
604	2	40303	External Port Data 3	R/RW	0	0 ~ 4,095	-
606	2	40304	External Port Data 4	R/RW	0	0 ~ 4,095	-
634	1	N/A	Indirect Data 1	RW	0	0 ~ 255	-
635	1	N/A	Indirect Data 2	RW	0	0 ~ 255	-
636	1	N/A	Indirect Data 3	RW	0	0 ~ 255	-
...
761	1	N/A	Indirect Data 128	RW	0	0 ~ 255	-

Control Table Description

CAUTION : Data in the EEPROM Area can only be written when the value of Torque Enable(512) is cleared to 0.

Model Number(0)

This address stores model number of the device.

Model Name	Model Number
PH42-20-S300-R	2,000 (0x07D0)

Firmware Version(6)

This address stores the firmware version of the DYNAMIXEL.

地址：北京市亦庄经济开发区凉水河二街8号大族企业湾7号楼A座2层 邮编：100176
 网址：www.bjrobot.com 邮箱：znj@bjrobot.com 全国服务热线：400 099 1872

ID(7)

The ID is a unique value in the network to identify each device with an Instruction Packet.

0~252 (0xFC) values can be used as an ID, and 254(0xFE) is occupied as a broadcast ID.

The Broadcast ID(254, 0xFE) can send an Instruction Packet to all connected devices simultaneously.

NOTE : Please avoid using an identical ID for multiple devices. You may face communication failure or may not be able to detect devices with an identical ID. Also ID(7) is in the EEPROM area, Torque Enable(512) should be set to 0 to change the ID.

Baud Rate(8)

Baud Rate determines serial communication speed between controller and device.

Value	Baud Rate	Actual Baud Rate	Margin of Error
9	10,500,000 (10.5M)	10,500,000	0.000%
8	6,000,000 (6M)	6,000,000	0.000%
7	4,500,000 (4.5M)	4,421,053	-1.176%
6	4,000,000 (4M)	4,000,000	0.000%
5	3,000,000 (3M)	3,000,000	0.000%
4	2,000,000 (2M)	2,000,000	0.000%
3	1,000,000 (1M)	1,000,000	0.000%
2	115,200	115,226	0.023%
1(Default)	57,600	57,613	0.023%
0	9,600	9,600	0.000%

NOTE : Less than 3% of the baud rate error margin will not affect to UART communication.

NOTE : For the stable communication with higher baudrate, configure USB Latency value to the lower.

USB Latency Setting

Return Delay Time(9)

After the device receives an Instruction Packet, it delays transmitting the Status Packet for Return Delay Time(9).

For instance, if the Return Delay Time(9) is set to ‘10’, the Status Packet will be returned after

20[μ sec] from when the Instruction Packet is received.

Unit	Value Range	Description
2 [μ sec]	0 ~ 254	Default Value: '250' (500 [μ s]), Maximum Value: 508 [μ s]

WARNING : Modbus-RTU dose not support Return Delay Time(9).

Drive Mode(10)

Drive Mode configures direction of rotation of the device.

Value	Mode	Description
0	Normal Mode	CCW(Positive), CW(Negative)
1	Reverse Mode	CCW(Negative), CW(Positive)

Operating Mode(11)

Operating mode of the device can be configured.

Value	Operating Mode	Description
0	Current Control Mode	The device only controls current(torque) regardless of speed and position. This mode is ideal for a gripper or a system that only uses current(torque) control or a system that has additional velocity/position controllers.
1	Velocity Control Mode	This mode controls velocity and current, but does not control position.
3(Default)	Position Control Mode	This mode controls position, velocity and current.
4	Extended Position Control Mode	This mode is similar to the Position Control Mode, but does not limited by the Position Limits. Therefore, the control range will not be bounded between 0 ~ 360 [$^{\circ}$] which enables multi-turn position control.
16	PWM(Voltage) Control Mode	Directly controls with PWM(Voltage) signal.

NOTE : Present Position(580) represents 4 byte continuous range from -2,147,483,648 to 2,147,483,647 when Torque is turned off regardless of Operating Mode(11).

However, Present Position(580) will be reset to an absolute position value of one full rotation in those cases:

When Operating Mode(11) is changed to Position Control Mode, Present Position(580) will be reset to an absolute position value of a full rotation.

When torque is turned on in Position Control Mode, Present Position(580) will be reset to an absolute position value of one full rotation.

When turning off the power supply on Extended Position Control Mode, Present Position(580) will be reset to an absolute position value of one full rotation.

Present Position(580) value can be affected by Homing Offset(20) .

Secondary ID(12)

Set the device' s Secondary ID. Secondary ID(12) is a value to identify each device, just like the ID(7). However, unlike ID(7), Secondary ID(12) is not a unique value. Therefore, devices with the same Secondary ID value form a group. The differences between Secondary ID(12) and ID(7) are as follows :

Secondary ID(12) is not a unique value. i.e., a lot of devices may have the same Secondary ID value.

ID(7) has a higher priority than Secondary ID(12). i.e., if Secondary ID(12) and ID(7) are the same, ID(7) will be applied first.

The EEPROM area of the Control Table cannot be modified with Secondary ID(12). Only the RAM area can be modified.

If Instruction Packet ID is the same as Secondary ID(12), the Status Packet will not be returned.

If the value of Secondary ID(12) is 253 or higher, the Secondary ID function is deactivated.

Values	Description
0 ~ 252	Activate Secondary ID function
253 ~ 255	Deactivate Secondary ID function, Default value '255'

The following are examples of operation when there are five devices with ID (7) set from 1 to 5.

Set all five devices' Secondary ID(12) to '5' .

Send Write Instruction Packet(ID = 1, LED Red(513) = 255).

Turn on the LED of the device with ID '1' and return the Status Packet.

Send Write Instruction Packet(ID = 5, LED Red(513) = 255).

Turn on the LED of five devices. However, Status Packet of the device with ID '5' will be returned.

Set the Secondary ID(12) of all five devices to '100' .

Send Write Instruction Packet(ID = 100, LED Red(513) = 0).

Turn off the LED of the five devices. However, as there is no device with ID '100', Status Packet is not returned.

WARNING : Modbus-RTU dose not support Secondary ID(12).

Protocol Type(13)

This address can switch between DYNAMIXEL Protocol and Modbus-RTU Protocol.

Modbus-RTU is supported DYNAMIXEL-P series Firmware V11 or above.

Value	Protocol	Description														
2	2.0	DYNAMIXEL Protocol 2.0														
10	Modbus-RTU	Industrial Standard Protocol														
		<table border="1"> <thead> <tr> <th>Function Code</th> <th>Description</th> <th>Address</th> <th>Device</th> </tr> </thead> <tbody> <tr> <td>03</td> <td>Read Holding Registers</td> <td>40001 ~ 40304</td> <td rowspan="3">DYNAMIXEL Control Table</td> </tr> <tr> <td>06</td> <td>Write Single Register</td> <td>40001 ~ 40304</td> </tr> <tr> <td>16</td> <td>Write Multiple Registers</td> <td>40001 ~ 40304</td> </tr> </tbody> </table>	Function Code	Description	Address	Device	03	Read Holding Registers	40001 ~ 40304	DYNAMIXEL Control Table	06	Write Single Register	40001 ~ 40304	16	Write Multiple Registers	40001 ~ 40304
		Function Code	Description	Address	Device											
		03	Read Holding Registers	40001 ~ 40304	DYNAMIXEL Control Table											
06	Write Single Register	40001 ~ 40304														
16	Write Multiple Registers	40001 ~ 40304														

WARNING : In order to change the Protocol Type of DYNAMIXEL-P series, please use DYNAMIXEL Wizard 2.0 as R+ Manager 2.0 does not support Modbus.

WARNING : Modbus-RTU dose not support the next data below.

Return Delay Time(9)

Secondary ID(12)

Status Return Level(516)

Registered Instruction(517)

Indirect Address

Indirect Data

Homing Offset(20)

Users can adjust the Home position by setting Home Offset(20). The Homing Offset value is added to the Present Position(580).

Present Position(580) = Actual Position + Homing Offset(20).

Unit	Value Range
1 [pulse]	-2,147,483,648 ~ 2,147,483,647

NOTE : Homing Offset(20) value that exceeds the range of (-90 ~ 90 [°]) will be ignored in Position Control Mode(Joint Mode).

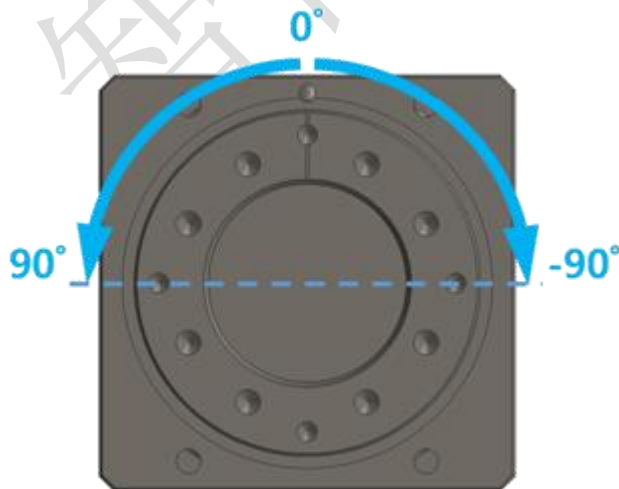

Moving Threshold(24)

This value determines whether the device is in motion or not. When the absolute value of Present Velocity(576) is greater than this value, Moving(570) is set to 1, otherwise it is cleared to 0.

Unit	Range
0.01 [rev/min]	0 ~ 2,920

Temperature Limit(31)

This value limits operating temperature.

When the Present Temperature(594) that indicates internal temperature of device is greater than the Temperature Limit(31), the Overheating Error Bit(0x04) in the Hardware Error Status(518) will be set.

If Overheating Error Bit(0x04) is configured in the Shutdown(63), Torque Enable(512) is cleared to '0' and Torque will be turned off.

For more details, please refer to the Shutdown(63) section.

Unit	Value Range	Description
About 1 [° C]	0 ~ 100	0 ~ 100 [° C]

CAUTION : Do not set the temperature lower/higher than the default value. When the temperature alarm shutdown occurs, wait for 20 minutes to cool the temperature before reuse. Keep using the product with high temperature can cause severe damage to the device.

Max/Min Voltage Limit(32, 34)

These values are maximum and minimum operating voltages.

When the Present Input Voltage(592) exceeds the range of Max Voltage Limit(32) and Min Voltage Limit(34), Input Voltage Error Bit(0x01) is set in the Hardware Error Status(518) and Alert Bit(0x80) is set in the Error field of the Status Packet.

If Input Voltage Error Bit(0x10) is configured in the Shutdown(63), Torque Enable(512) is cleared to '0' and Torque is disabled. For more details, please refer to the Shutdown(63) section.

Unit	Value Range
about 0.1 [V]	150 ~ 350

PWM Limit(36)

This value indicates the maximum PWM output.

Goal PWM(548) cannot be configured with any values exceeding PWM Limit(36).

PWM Limit(36) is commonly applied in all operating mode as an output limit, therefore decreasing PWM output will also decrease torque and velocity of the device.

For more details, please refer to the Gain section of each operating mode.

Value	Description
0 ~ 2,009	2,009 = 100 [%] Output

Current Limit(38)

This value indicates the maximum current limit.

Goal Current(550) cannot be configured with any values exceeding Current Limit(38). Attempting to write an invalid value will fail and set the Limit Error Bit in the error field of the Status Packet.

Unit	Range
1 [mA]	0 ~ 4,500

Acceleration Limit(40)

This value indicates the maximum acceleration limit.

Profile Acceleration(556) cannot be configured with any values exceeding Acceleration Limit(40). Attempting to write an invalid value will fail and set the Limit Error Bit in the error field of the Status Packet.

Unit	Range
1 [rev/min ²]	0 ~ 4,306,173

Velocity Limit(44)

This value indicates maximum velocity of Goal Velocity(552) and Profile Velocity(562). Goal Velocity(552) and Profile Velocity(562) cannot be configured with any values exceeding Velocity Limit(44). Attempting to write an invalid value will fail and set the Limit Error Bit in the error field of the Status Packet.

Unit	Range
0.01 [rev/min]	0 ~ 2,920

Max/Min Position Limit(48, 52)

These values limit maximum and minimum desired positions within a single turn(-303,750 ~ 303,750).

The Goal Position(564) can't exceed these values.

Attempting to write an exceeding value will fail and result in receiving a Limit Error Bit from the Status Packet.

Unit	Default Value	Range
1 [pulse]	-303,454 ~ 303,454	-303,750 ~ 303,750

NOTE: In Extended Position Control Mode, these limits will be ignored.

External Port Mode, External Port Data

External ports that can be used for various purposes are provided.

The property of each port is configured by the External Port Mode (56 ~ 59) and data of external port is controlled by the External Port Data(600 ~ 607).

The signal of External Port can be controlled or checked via External Port Data.

The External Port is not electrically insulated, therefore, abide by the electrical specifications.

Shielded cable or twisted paired cable reduces signal noise and error.

Shorter cable increases accuracy of the measurement.

Item	Description
Voltage	0 ~ 3.3 [V] VESD(HBM) : 2[kV]

Item	Description
Current	0 ~ 5 [mA]

※ VESD(HBM) : ESD(Electrostatic Discharge) Voltage(human body model)

Function	External Port Mode	External Port Data	Access	Details
Analogue Input	0	Converts External Port signal to digital value External Data = signal x (4,095 / 3.3)	R	Resolution : 12[bit] (0 ~ 4,095)
Digital Output Push-Pull	1	0 : Set External Port output to 0[V] 1 : Set External Port output to 3.3[V]	W	Output High level(VOH) : 2.4 [V] (min) Output Low level(VOL) : 0.5 [V] (max)
Digital Input Pull-Up	2	0 : External Port input is 0[V] 1 : External Port input is 3.3[V] or Open	R	Input High level(VIH) : 2.3 [V] (min) Input Low level(VIL) : 1.0 [V] (max) Pull-Up : 40 [k Ω] (typ)
Digital Input Pull-Down	3 (Default)	0 : External Port input is 0[V] or Open 1 : External Port input is 3.3[V]	R	Input High level(VIH) : 2.3 [V] (min) Input Low level(VIL) : 1.0 [V] (max) Pull-Down : 40 [k Ω] (typ)

WARNING : The External Port is not electrically insulated, therefore, abide by the electrical specifications.

If the electrical specification is exceeded or there is a problem with the signal connection, special caution is required because DYNAMIXEL can be damaged.

Be careful not to cause electric shock by static electricity (ESD), short circuit, open circuit.

Be careful not to let water or dust get into the External Port connector.

If you are not using the External Port, remove the cable.

To connect or disconnect the External Port, proceed with power off.

Do not connect the GNDext pin of External Port directly to the GND pin of DYNAMIXEL connector. Noise from power may affect on the External Port.

External expansion port location and pin function

Remove bolts and cover plate to reveal External Port connector.



Pin Number



Pin 1	Pin 2	Pin 3	Pin 4	Pin 5	Pin 6
GND	3.3V	PORT1	PORT2	PORT3	PORT4

Shutdown(63)

The DYNAMIXEL can protect itself by detecting dangerous situations that could occur during the operation.

Each Bit is inclusively processed with the ‘OR’ logic, therefore, multiple options can be generated.

For instance, when ‘0x05’ (binary : 00000101) is defined in Shutdown(63), DYNAMIXEL can detect both Input Voltage Error(binary : 00000001) and Overheating Error(binary : 00000100).

If those errors are detected, Torque Enable(512) is cleared to ‘0’ and the motor output becomes 0 [%].

REBOOT is the only method to reset Torque Enable(512) to ‘1’ (Torque ON) after the shutdown. Check Hardware Error Bit(0x80) in a error field of Status Packet or a present status via Hardware Error Status(518) The followings are detectable situations.

Bit	Item	Description
Bit 7	-	Not used, always ‘0’
Bit 6	-	Not used, always ‘0’

Bit	Item	Description
Bit 5	Overload Error(Default)	Detect persistent load that exceeds maximum output
Bit 4	Electrical Shock Error(Default)	Detect electric shock on the circuit or insufficient power to operate the motor
Bit 3	Motor Encoder Error(Default)	Detect malfunction of the motor encoder
Bit 2	OverHeating Error	Detect internal temperature exceeds the configured operating temperature
Bit 1	Motor Hall Sensor Error(Default)	Motor hall sensor value exceeds normal range
Bit 0	Input Voltage Error	Detect input voltage exceeds the configured operating voltage

NOTE :

If Shutdown occurs, Dynamic brake will be activated.

If Shutdown occurs, LED will flicker every second.

If Shutdown occurs, reboot the device.

H/W REBOOT : Turn off and turn on the power again

S/W REBOOT : Transmit REBOOT Instruction (For more details, refer to the Reboot section of e-Manual.)

Indirect Address, Indirect Data

Indirect Address and Indirect Data are useful when accessing multiple remote addresses in the Control Table as sequential addresses. Sequential address increases the efficiency of Instruction Packet. Addresses that can be defined as Indirect Address are limited to RAM area(Address 512 ~ 606). If specific address is allocated to Indirect Address, Indirect Address inherits features and properties of the Data from the specific Address. Property includes Size(Byte length), value range, and Access property(Read Only, Read/Write).

For instance, allocating 513(which is the Address of red LED) to Indirect Address 1(168) and writing 255 to the Indirect Data 1(634) will turn on the red LED. The actual value of LED Red(513) will also be set as 255.

If a specific item has address longer than 2 byte, each address byte has to be sequentially configured in the Indirect Address.

Example 1 : Allocating 1 byte LED Red(513) to Indirect Data 1(634).

Indirect Address 1(168) : write 513 which is the address of LED Red.

Set Indirect Data 1(634) to 255 : The value of LED Red(513) will automatically set as 255 and LED will be turned on.

Set Indirect Data 1(634) to 0 : The value of LED Red(513) will automatically set as 0 and LED will be turned off.

Example 2 : To allocate 4 byte Goal Position(564) to Indirect Data 2(635), 4 sequential bytes have

地址：北京市亦庄经济开发区凉水河二街8号大族企业湾7号楼A座2层 邮编：100176

网址：www.bjrobot.com 邮箱：znj@bjrobot.com 全国服务热线：400 099 1872

to be allocated.

Indirect Address 2(170) : Write 564 which is the first address of Goal Position.

Indirect Address 3(172) : Write 565 which is the second address of Goal Position.

Indirect Address 4(174) : Write 566 which is the third address of Goal Position.

Indirect Address 5(176) : Write 567 which is the fourth address of Goal Position.

Write 4 byte desired position value of 250,961(0x0003D451) to Indirect Data 2 ~ 5 : The value of Goal Position(564) will reflect these changes and set as 0x0003D451 as shown below(Little Endian).

Indirect Data Address	Goal Position Address	Saved HEX Value
635	564	0x51
636	565	0xD4
637	566	0x03
638	567	0x00

NOTE : In order to allocate Data in the Control Table longer than 2[byte] to Indirect Address, all address must be allocated to Indirect Address like the above Example 2.

WARNING : Modbus-RTU dose not support Indirect Address and Indirect Data.

Torque Enable(512)

Controls Torque ON/OFF. Writing ‘1’ to this address will turn on the Torque and all Data in the EEPROM area will be protected.

Value	Description
0(Default)	Turn off the torque
1	Turn on the torque and lock EEPROM area

NOTE : Present Position(580) can be reset when Operating Mode(11) and Torque Enable(512) are updated. For more details, please refer to the Homing Offset(20) and Present Position(580).

RGB LED(513)

These addresses control the RGB LED of the device. When Shutdown occurs, LED cannot be controlled.

Address	Color	Range
513	Red	0 ~ 255
514	Green	0 ~ 255
515	Blue	0 ~ 255

NOTE : The LED indicates present status of the device.

Status	LED Representation
Booting	Green LED flickers once

Status	LED Representation
Factory Reset	Green LED flickers 4 times
Alarm	Red LED flickers

Status Return Level(516)

This value decides how to return Status Packet when the device receives an Instruction Packet.

Value	Responding Instructions	Description
0	PING Instruction	Status Packet will not be returned for all Instructions
1	PING Instruction READ Instruction	Status Packet will be returned only for READ Instruction
2	All Instructions	Status Packet will be returned for all Instructions

NOTE : If the ID of Instruction Packet is set to Broad Cast ID(0xFE), Status Packet will not be returned for READ and WRITE Instructions regardless of Status Return Level. For more details, please refer to the Status Packet section of Protocol 2.0.

WARNING : Modbus-RTU dose not support Status Return Level(516).

Registered Instruction(517)

Value	Description
0	REG_WRITE instruction is not received.
1	REG_WRITE instruction is received.

NOTE : If ACTION instruction is executed, the value will be changed to 0.

WARNING : Modbus-RTU dose not support Registered Instruction(517).

Hardware Error Status(518)

This value indicates hardware error status. For more details, please refer to Shutdown(63) section.

Velocity PI Gain(524, 526), Feedforward 2nd Gains(536)

These values indicate Gains of Velocity Control Mode. Gains of the device' s internal controller can be calculated from Gains of the Control Table as shown below. Velocity P Gain of the device' s internal controller is abbreviated to KVP and that of the Control Table is abbreviated to KVP(TBL).

	Controller Gain	Range	Description
Velocity I Gain(524)	KVI	0 ~ 32,767	Velocity Integral Gain
Velocity P Gain(526)	KVP	0 ~ 32,767	Velocity Proportional Gain
Feedforward 2nd Gain(536)	KFF2nd	0 ~ 32,767	Acceleration Feedforward Gain

Below figure is a block diagram describing the velocity controller in Velocity Control Mode.

When the instruction is received by the device, it takes following steps until driving the device.

An Instruction from the user is transmitted via communication bus, then registered to Goal

地址：北京市亦庄经济开发区凉水河二街8号大族企业湾7号楼A座2层 邮编：100176

网址：www.bjrobot.com 邮箱：znj@bjrobot.com 全国服务热线：400 099 1872

Velocity(552).

Goal Velocity(552) is converted to desired velocity trajectory by Profile Acceleration(556).

The desired velocity trajectory is stored at Velocity Trajectory(584).

PI controller calculates PWM output for the motor based on the desired velocity trajectory.

Goal PWM(584) sets a limit on the calculated PWM output and decides the final PWM value.

The final PWM value is applied to the motor through an Inverter, and the device is driven.

Results are stored at Present Position(580), Present Velocity(576), Present PWM(572) and Present Current(574).

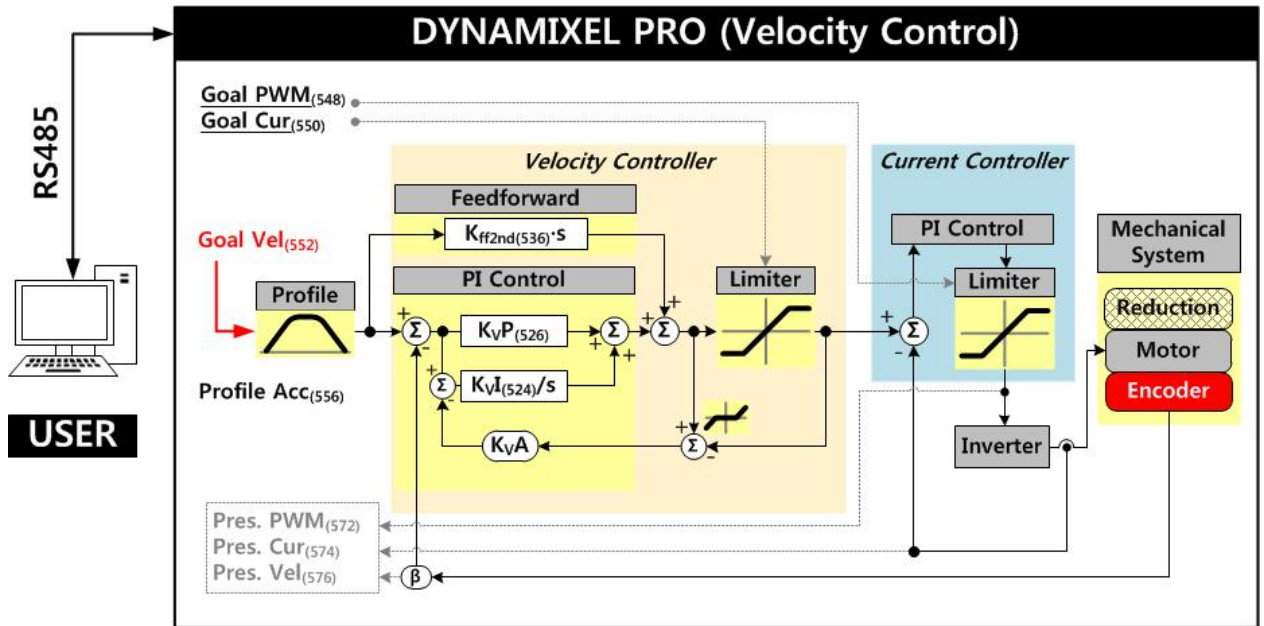

NOTE : K_vA stands for Anti-windup Gain that cannot be modified by users. For more details about the PID controller, please refer to the PID Controller at wikipedia.

Position PID Gain(528, 530, 532), Feedforward 1st Gains(538)

These Gains are used in Position Control Mode and Extended Position Control Mode. Gains of device' s internal controller can be calculated from Gains of the Control Table as shown below. Position P Gain of device' s internal controller is abbreviated to KPP and that of the Control Table is abbreviated to KPP(TBL).

	Controller Gain	Range	Description
Position D Gain(528)	KPD	0 ~ 32,767	Position Derivative Gain
Position I Gain(530)	KPI	0 ~ 32,767	Position Integral Gain
Position P Gain(532)	KPP	0 ~ 32,767	Position Proportional Gain
Feedforward 1st Gain(538)	KFF1st	0 ~ 32,767	Velocity Feedforward Gain

Below figure is a block diagram describing the position controller in Position Control Mode and Extended Position Control Mode. When the instruction is received by the device, it takes following steps until driving the device.

An Instruction from the user is transmitted via communication bus, then registered to Goal Position(564).

Goal Position(564) is converted to desired position trajectory and desired velocity trajectory by Profile Velocity(560) and Profile Acceleration(556).

The desired position trajectory and desired velocity trajectory is stored at Position Trajectory(588) and Velocity Trajectory(584) respectively.

Feedforward and PID controller calculate PWM output for the motor based on desired trajectories.

Goal PWM(548) sets a limit on the calculated PWM output and decides the final PWM value.

The final PWM value is applied to the motor through an Inverter, and the device is driven.

Results are stored at Present Position(580), Present Velocity(576), Present PWM(572) and Present Current(574).

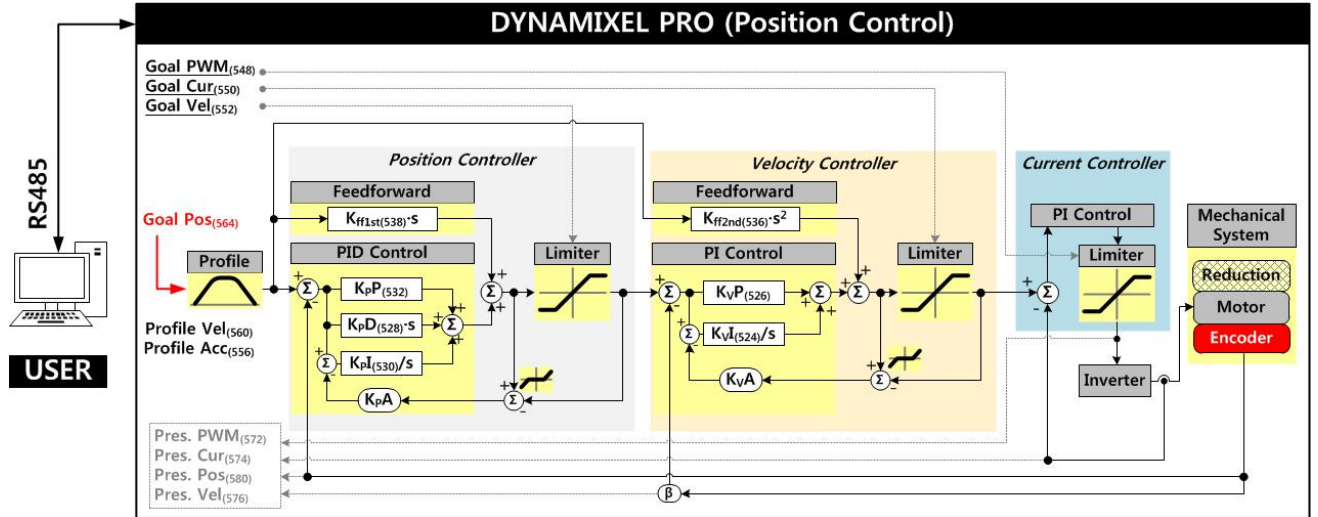

NOTE : In case of PWM Control Mode, both PID controller and Feedforward controller are deactivated while Goal PWM(548) value is directly controlling the motor through an Inverter. In this manner, users can directly control the supplying voltage of the motor.

NOTE : Ka is an Anti-windup Gain that cannot be modified by users.

Bus Watchdog(546)

Bus Watchdog(546) is a safety feature(Fail-safe) that stops the device if the communication(RS485, TTL) between the controller and the device is disconnected due to an unidentified error.

The “communication” can be seen as all the Instruction Packets defined in the protocol.

	Value	Description
Unit	20 [msec]	-
Range	0	Deactivates Bus Watchdog Function and clears Bus Watchdog Error
Range	1 ~ 127	Activates Bus Watchdog
Range	-1	Bus Watchdog Error Status

The Bus Watchdog monitors the communication interval time between the controller and the device when Torque Enable(512) is ‘1’.

If the measured communication interval time is longer than Bus Watchdog(546), the device will be stopped and Bus Watchdog(546) value will be set to ‘-1’ (Bus Watchdog Error).

If Bus Watchdog Error occurs, goal values such as Goal PWM(548), Goal Current(550), Goal Velocity(552) and Goal Position(564) will be changed to read-only-access.

Therefore, attempting to write a new value to these address will fail and return Range Error in the Status Packet. Writing '0' to Bus Watchdog(546) will clear the Bus Watchdog Error.

NOTE : For details of Range Error, please refer to the Protocol 2.0.

The following is the example of Bus Watchdog function.

After setting the Operating Mode(11) to Velocity Control Mode, change the Torque Enable(512) to 1.

If 50 is written to the Goal Velocity(552), the device will rotate in CCW direction.

Change the value of Bus Watchdog(546) to 100(2,000 [ms]). (Activate Bus Watchdog Function)

If no instruction packet is received within 2,000 [ms], the device will stop with the predefined decelerating value.

Bus Watchdog(546) value is set to -1 (Bus Watchdog Error). At this time, the access property of goal values will be changed to read-only.

If 150 is written to the Goal Velocity(552), Range Error will be returned via Status Packet.

If Bus Watchdog(546) value is changed to 0, Bus Watchdog Error will be cleared.

If 150 is written in the Goal Velocity(552), the device will rotate in CCW direction.

Goal PWM(548)

In case of PWM Control Mode, both PID controller and Feedforward controller are deactivated while Goal PWM(548) value is directly controlling the motor through an Inverter.

In other control modes, this value is used to limit the output torque.

This value cannot exceed PWM Limit(36).

Please refer to the Gain section in order to see how Goal PWM(548) affects to different control modes.

Range	Description
-PWM Limit(36) ~ PWM Limit(36)	Initial Value of PWM Limit(36) : 2,009

Goal Current(550)

In Current Control Mode, Goal Current(550) can be used to set the desired current. This value sets a current limit of the current controller in Velocity Control Mode, Position Control Mode and Extended Position Control Mode.

This value cannot exceed Current Limit(38).

Goal Velocity(552)

In Velocity Control Mode, Goal Velocity(552) can be used to set the desired velocity.

This value cannot exceed Velocity Limit(44).

Goal Velocity(552) is used to limit the input(velocity) of velocity controller in Position Control Mode and Extended Position Control Mode.

Profile Acceleration(556)

The acceleration of Profile can be set with this value. Profile Acceleration(556) can be used in Velocity Control Mode, Position Control Mode and Extended Position Control Mode. Profile Acceleration(556) must be a positive number and cannot exceed Acceleration Limit(40).

NOTE : When Profile Velocity(560) is set to '0', Profile Acceleration will be ignored.

Profile Velocity(560)

The Maximum velocity for Profile can be set with this value.

Profile Velocity(560) can be used in Position Control Mode and Velocity Control Mode.

Profile Velocity(560) cannot exceed Velocity Limit(44).

Velocity Control Mode only uses Profile Acceleration(556) and Profile Velocity(560) will be ignored.

Unit	Value Range	Description
0.01 [rev/min]	0 ~ Velocity Limit(44)	'0' stands for the infinite velocity

The Profile is an acceleration/deceleration control technique to reduce vibration, noise and load on the motor by controlling dramatically changing velocity and acceleration.

It is also called Velocity Profile as it controls acceleration and deceleration based on velocity.

This device provides the following 3 types of profile.

Profiles are usually selected by the combination of Profile Velocity(560) and Profile Acceleration(556).

Trapezoidal Profile is exceptionally chosen with additional factor: travel distance(Δ Pos, the distance between desired position and present position).

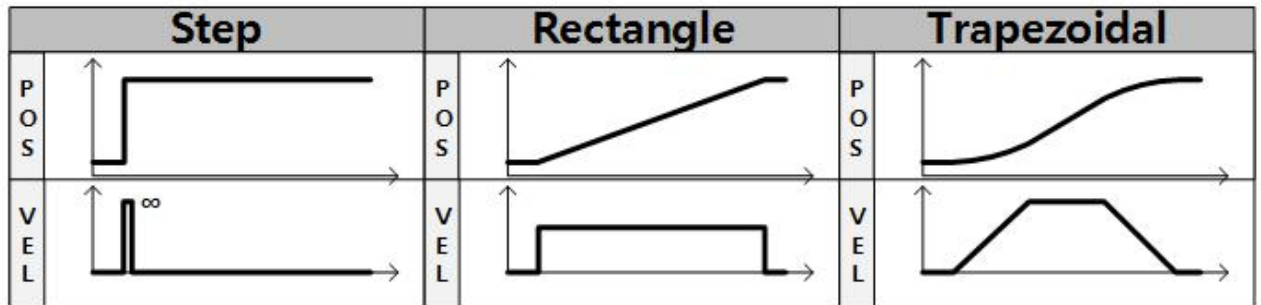

When given Goal Position(564), the device's profile creates desired velocity trajectory based on present velocity(initial velocity of the Profile).

When the device receives updated desired position via Goal Position(564) while it is moving toward the previous desired position, velocity will smoothly changed for the new desired velocity trajectory.

Maintaining velocity continuity while updating the desired velocity trajectory is called "Velocity Override".

For easier calculation in this example, let's assume that the initial velocity of the Profile is 0.

The following explains how Profile processes Goal Position(564).

An Instruction is received via communication bus, then registered in Goal Position(564).

Accelerating time(t_1) is calculated from Profile Velocity(560) and Profile Acceleration(556).

Profile type is decided based on Profile Velocity(560), Profile Acceleration(556) and total travel distance(Δ Pos, the distance difference between desired position and present position).

Selected Profile type is stored at Moving Status(571).(Refer to the Moving Status(571))

The device is driven by the calculated desired trajectory from Profile.

The desired velocity trajectory and the desired position trajectory calculated by the Profile are saved at Velocity Trajectory(584) and Position Trajectory(588) respectively.

Condition	Types of Profile
-----------	------------------

Condition	Types of Profile
Profile Velocity(560) = 0	Profile not used (Step Instruction)
(Profile Velocity(560) \neq 0) & (Profile Acceleration(556) = 0)	Rectangular Profile
(Profile Velocity(560) \neq 0) & (Profile Acceleration(556) \neq 0)	Trapezoidal Profile

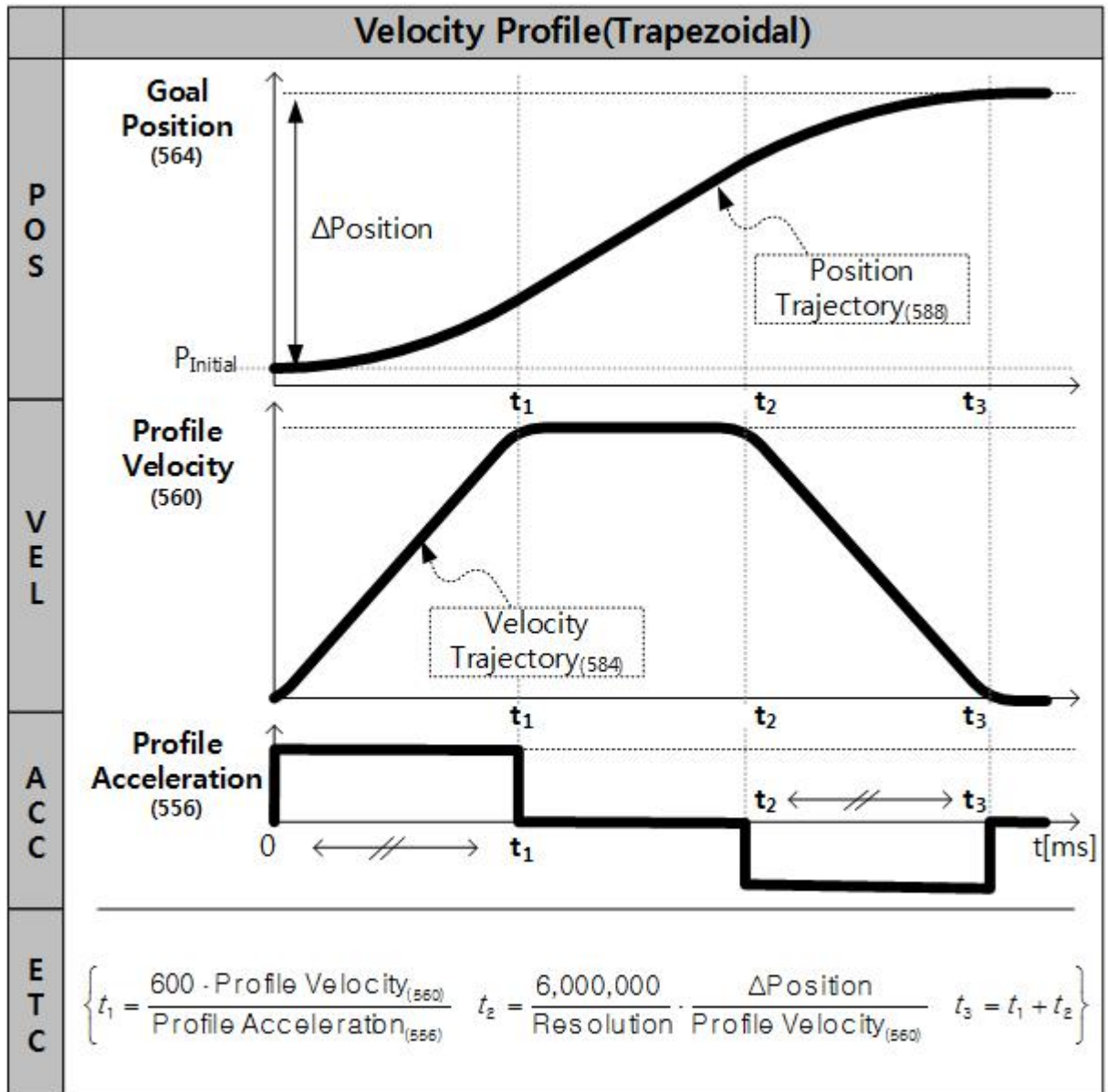

NOTE : Velocity Control Mode only uses Profile Acceleration(556).

Step and Trapezoidal Profiles are supported and Velocity Override is supported as well.

Acceleration time(t_1) can be calculated as below equation.

$$t_1 = 600 * \{ \text{Goal Velocity}(552) / \text{Profile Acceleration}(556) \}$$

Goal Position(564)

Desired position can be set with Goal Position(564).

地址：北京市亦庄经济开发区凉水河二街8号大族企业湾7号楼A座2层 邮编：100176

网址：www.bjrobot.com

邮箱：znj@bjrobot.com

全国服务热线：400 099 1872

This value must be in between Min Position Limit(52) and Max Position Limit(48) in Position Control Mode, while Extended Position Control Mode uses a value range between -2,147,483,648 ~ 2,147,483,647.

NOTE : Present Position(580) represents 4 byte continuous range from -2,147,483,648 to 2,147,483,647 when Torque is turned off regardless of Operating Mode(11).

However, Present Position(580) will be reset to an absolute position value of one full rotation in those cases:

When Operating Mode(11) is changed to Position Control Mode, Present Position(580) will be reset to an absolute position value of a full rotation.

When torque is turned on in Position Control Mode, Present Position(580) will be reset to an absolute position value of one full rotation.

When turning off the power supply on Extended Position Control Mode, Present Position(580) will be reset to an absolute position value of one full rotation.

Present Position(580) value can be affected by Homing Offset(20) .

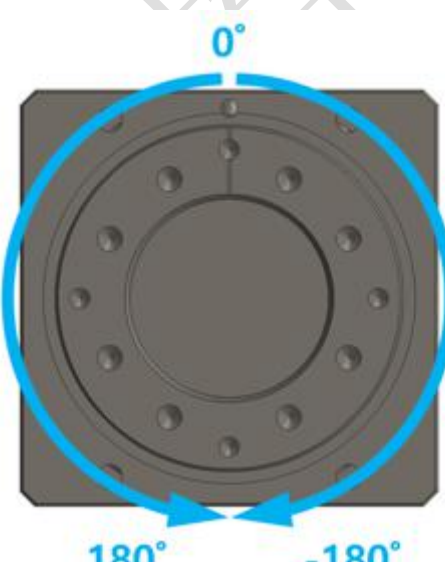
Angle Range	Value Range	Description
-180 [°] ~ 180 [°]	-303,750 ~ 303,750	

Realtime Tick(568)

This value indicates device' s internal time.

Unit	Value Range	Description
1 [msec]	0 ~ 32,767	The value resets to '0' when it exceeds 32,767

Moving(570)

This value indicates whether the device is in motion or not. If absolute value of Present Velocity(576) is greater than Moving Threshold(24), Moving(570) is set to '1'. Otherwise, it will be cleared to '0' .

However, this value will always be set to '1' regardless of Present Velocity(576) while Profile is in progress with Goal Position(564) instruction.

Moving Status(571)

This value provides additional information about the movement. In-Position Bit(0x01) only works

with Position Control Mode and Extended Position Control Mode.

		Details	Description
Bit 7	0x80	-	Unused
Bit 6	0x40	-	Unused
Bit 5 ~ Bit 4	0x30	Profile Type(0x30) Profile Type(0x10) Profile Type(0x00)	Trapezoidal Velocity Profile Rectangle Velocity Profile Profile unused(Step)
Bit 3	0x08	-	Unused
Bit 2	0x04	-	Unused
Bit 1	0x02	-	Unused
Bit 0	0x01	In-Position	The device is reached to desired position

Present PWM(572)

This value indicates current PWM. For more details, please refer to the Goal PWM(548).

Present Current(574)

This value indicates the present current flowing on the motor. For more details, please refer to the Goal Current(550).

Present Velocity(576)

This value indicates the present Velocity. For more details, please refer to the Goal Velocity(552).

Present Position(580)

This value indicates present Position. For more details, please refer to the Goal Position(564).

NOTE : Present Position(580) represents 4 byte continuous range from -2,147,483,648 to 2,147,483,647 when Torque is turned off regardless of Operating Mode(11).

However, Present Position(580) will be reset to an absolute position value of one full rotation in those cases:

When Operating Mode(11) is changed to Position Control Mode, Present Position(580) will be reset to an absolute position value of a full rotation.

When torque is turned on in Position Control Mode, Present Position(580) will be reset to an absolute position value of one full rotation.

When turning off the power supply on Extended Position Control Mode, Present Position(580) will be reset to an absolute position value of one full rotation.

Present Position(580) value can be affected by Homing Offset(20) .

Velocity Trajectory(584)

This is a desired velocity trajectory created by Profile. Operating method can be differ by control mode. For more details, please refer to the Profile Velocity(560).

Velocity Control Mode : When Profile reaches to the endpoint, Velocity Trajectory(136) becomes equal to Goal Velocity(104).

Position Control Mode, Extended Position Control Mode : The desired Velocity Trajectory is used to create Position Trajectory(588). When Profile reaches to an endpoint, Velocity Trajectory(584)

is set to '0' .

Position Trajectory(588)

This is a desired position trajectory created by Profile. This value is only used in Position Control Mode and Extended Position Control Mode. For more details, please refer to the Profile Velocity(560).

Present Input Voltage(592)

This value indicates present voltage that is being supplied to the device. For more details, please refer to the Max/Min Voltage Limit(32, 34).

Present Temperature(594)

This value indicates internal temperature of the device. For more details, please refer to the Temperature Limit(31).

How to Assemble

Option Frame Assembly

FRP42-H121K Set

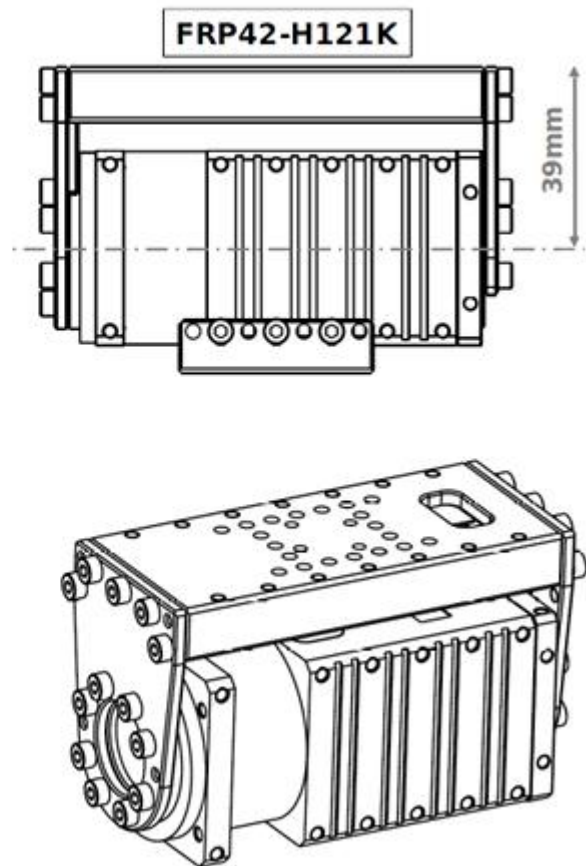
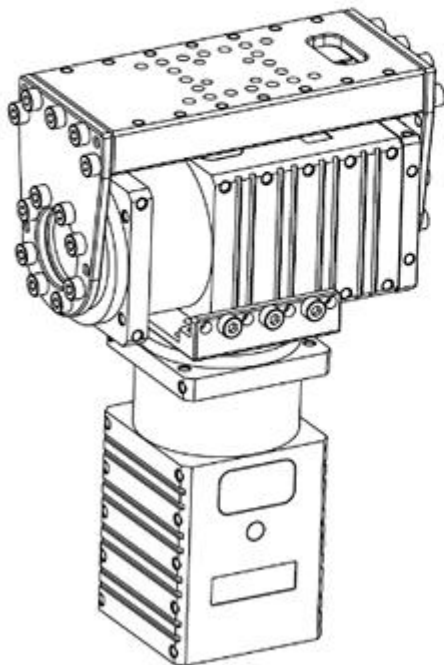

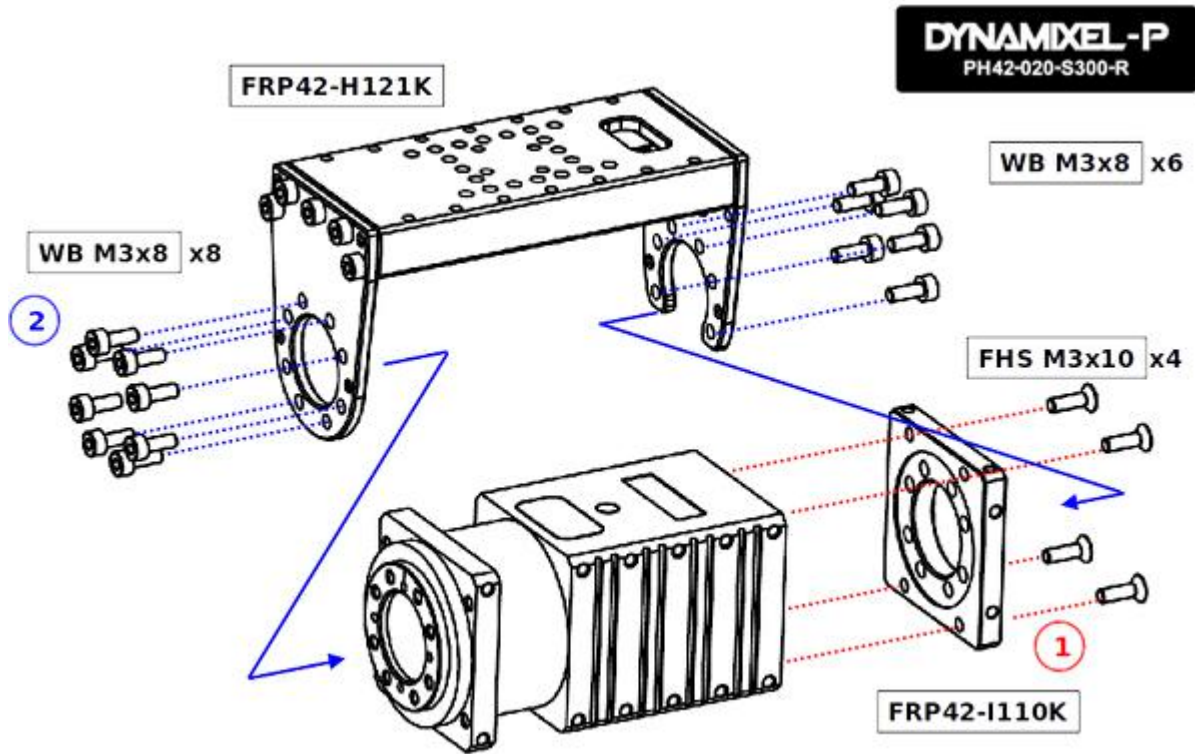

Maintenance

Reference

NOTE Compatibility Guide

Harness Compatibility

Certifications

Please inquire us for information regarding unlisted certifications.

FCC

Note: This equipment has been tested and found to comply with the limits for a Class A digital device, pursuant to part 15 of the FCC Rules. These limits are designed to provide reasonable protection against harmful interference when the equipment is operated in a commercial environment. This equipment generates, uses, and can radiate radio frequency energy and, if not installed and used in accordance with the instruction manual, may cause harmful interference to radio communications. Operation of this equipment in a residential area is likely to cause harmful interference in which case the user will be required to correct the interference at his own expense.

WARNING

Any changes or modifications not expressly approved by the manufacturer could void the user's authority to operate the equipment.

Connector Information

Item	RS-485	Power	External Port
Pinout	1 GND 2 VDD 3 DATA+	1 GND 2 VDD	1 GND 2 VDD 3 PORT 1

Item	RS-485 4 DATA-	Power	External Port 4 PORT 2 5 PORT 3 6 PORT 4
Diagram			
Housing	 JST EHR-4	 MOLEX 39-01-2020	 MOLEX 51021-0600
PCB Header	 JST B4B-EH-A	 MOLEX 39-28-1023 MOLEX 87427-0242	 MOLEX 53047-0610
Crimp Terminal	JST SEH-001T	MOLEX 39-00-0038	MOLEX 50079-8100
Wire Gauge	21 AWG	20 AWG	26 AWG

WARNING: Check the pinout! The pinout of DYNAMIXEL can differ from the pinout of connector manufacturer.

WARNING: Before operating DYNAMIXEL PRO and DYNAMIXEL-P series, please supply power through 24V power port.

Communication Circuit

To control DYNAMIXEL-P series with a custom made Main Controller, the signal of Main Controller UART should be converted into RS-485 signal. The following is a recommended conversion circuit diagram.

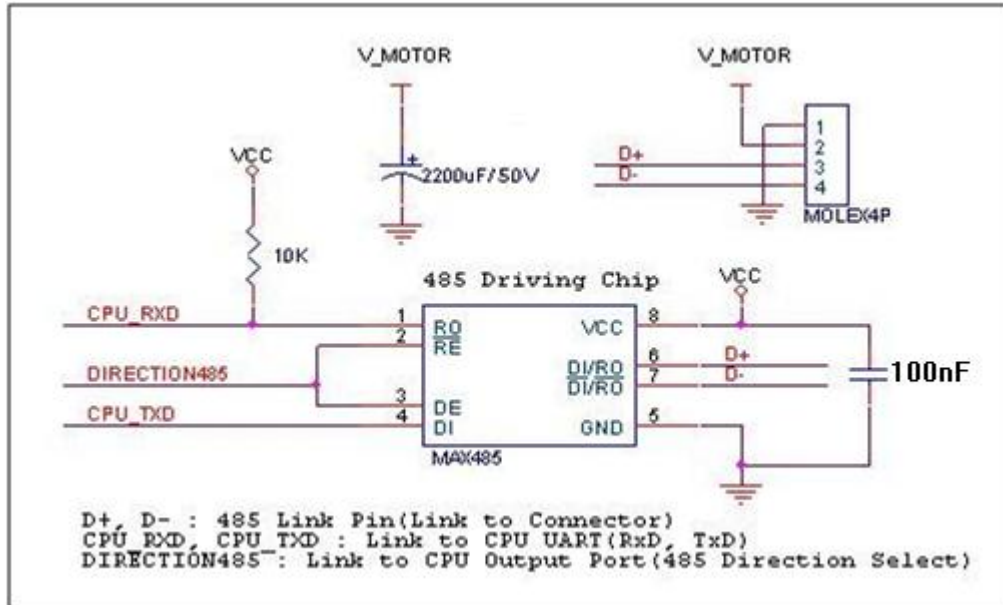

MAX485 Datasheet

The power is supplied via Pin1(-) and Pin2(+) of DYNAMIXEL. (The above circuit is built into DYNAMIXEL-only controllers)

In the above circuit diagram, the direction of data signal of TxD and RxD in the TTL Level is determined according to the level of DIRECTION485 as follows:

If DIRECTION485 = High : The CPU_TXD signal is transferred to D+ and D-.

If DIRECTION485 = Low : The D+ and D- signals are transferred to CPU_RXD.

Pin Arrangement

Connector pin arrangement is shown below. DYNAMIXEL-P series has two 4-pin connectors arranged in pin-2-pin configuration. In this arrangement there's no priority in the connector order and DYNAMIXEL-P series can be driven like the MX-series.

Additionally there is a 2-pin connector dedicated for power input for high-current operations.

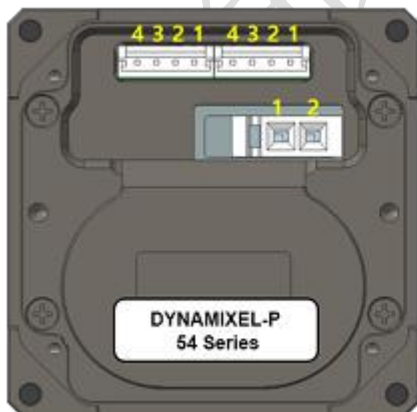

4 Pin Function

- 1 : GND
- 2 : VDD (24V)
- 3 : D+
- 4 : D-

2 Pin Function

- 1 : GND
- 2 : VDD (24V)



4 Pin Function

- 1 : GND
- 2 : VDD (24V)
- 3 : D+
- 4 : D-

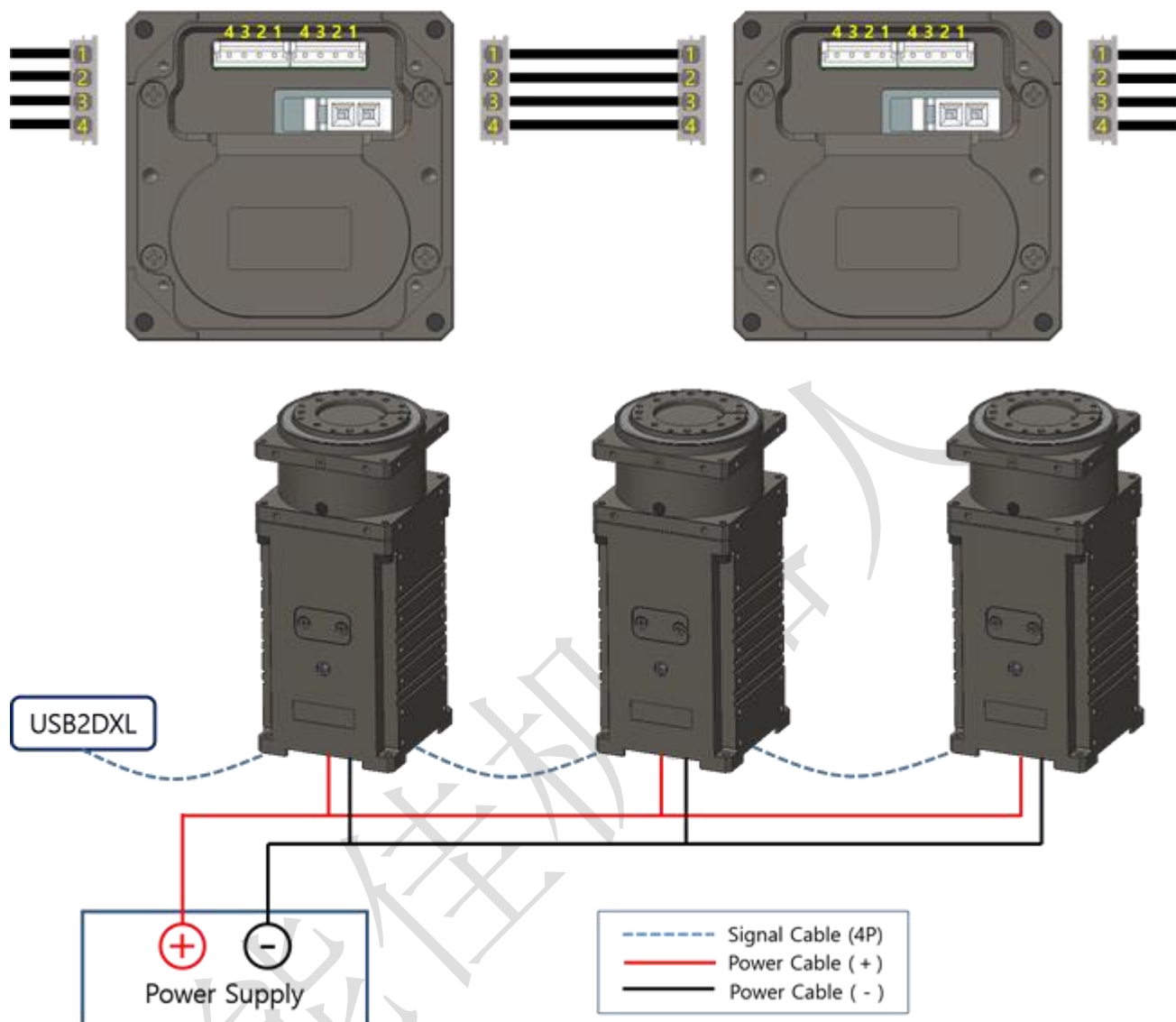

WARNING : When wiring please pay attention to the pin arrangement. Incorrectly connected DYNAMIXEL-P series may be damaged severely.