



New XL430-W250 (Released on 2018 3rd quarter)



Old XL430-W250 (This type has been discontinued)

Specifications

Item	Specifications
MCU	ARM CORTEX-M3 (72 [MHz], 32Bit)
Position Sensor	Contactless absolute encoder (12Bit, 360 [°]) Maker : ams(www.ams.com), Part No : AS5601
Motor	Cored
Baud Rate	9,600 [bps] ~ 4.5 [Mbps]
Control Algorithm	PID control
Resolution	4096 [pulse/rev]
Operating Modes	Velocity Control Mode Position Control Mode (0 ~ 360 [°]) Extended Position Control Mode (Multi-turn) PWM Control Mode (Voltage Control Mode)

Item	Specifications
Weight	57.2 [g]
Dimensions (W x H x D)	28.5 x 46.5 x 34 [mm]
Gear Ratio	258.5 : 1
Stall Torque	1.0 [N.m] (at 9.0 [V], 1.0 [A]) 1.4 [Nm] (at 11.1 [V], 1.3 [A]) 1.5 [Nm] (at 12.0 [V], 1.4 [A])
No Load Speed	47 [rev/min] (at 9.0 [V]) 57 [rev/min] (at 11.1 [V]) 61 [rev/min] (at 12.0 [V])
Operating Temperature	-5 ~ +72 [° C]
Input Voltage	6.5 ~ 12.0 [V] (Recommended : 11.1 [V])
Command Signal	Digital Packet
Protocol Type	TTL Half Duplex Asynchronous Serial Communication (8bit, 1stop, No Parity)
Physical Connection	TTL Multidrop Bus
ID	253 ID (0 ~ 252)
Feedback	Position, Velocity, Load, Realtime tick, Trajectory, Temperature, Input Voltage, etc
Part Material	Engineering Plastic
Standby Current	52 [mA]



DANGER

(May cause serious injury or death)

Never place items containing water, flammables, and solvents near product.

Never place fingers, arms, toes, and other body parts near product during operation.

Cut power off if product emits strange odors or smoke.

Keep product out of reach of children.

Check the power polarity before wiring.



CAUTION

(May cause injury or damage to product)

Do not operate the product at a temperature exceeding $-5 \sim +72$ [° C] range.

Do not insert sharp blades nor pins during product operation.

**ATTENTION**

(May cause injury or damage to product)

Do not disassemble or modify product.

Do not drop or apply strong shock to product.

Performance Graph

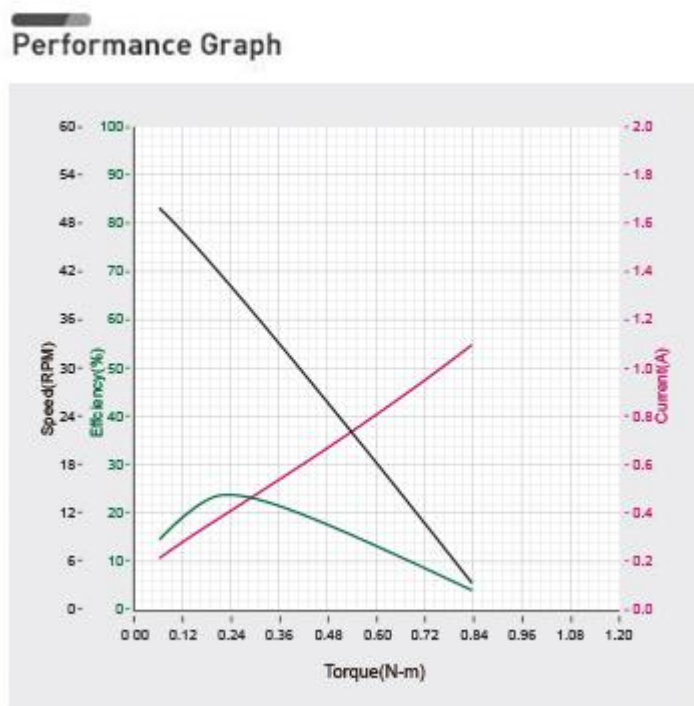

NOTE : The Max Torque and the Stall Torque of Performance Graph are different in measurement methods. Stall torque is a measured value of the momentary torque that it can reach. This is generally how RC servos are measured. The Performance graph is also called as N-T curves, which is measured with the gradually increasing load. The actual motor operation environment is closer to the performance graph, not stall torque method. For this reason, the performance graph is broadly used in the industrial field. Generally, Max Torque of the Performance Graph is less than the Stall Torque.

CAUTION : When supplying power

It is recommended using ROBOTIS controller or SMPS2DYNAMIXEL.

Do not connect or disconnect DYNAMIXEL when power is being supplied.

Control Table

The Control Table is a structure of data implemented in the device. Users can read a specific Data to get status of the device with Read Instruction Packets, and modify Data as well to control the device with WRITE Instruction Packets.

Control Table, Data, Address

The Control Table is a structure that consists of multiple Data fields to store status or to control the device. Users can check current status of the device by reading a specific Data from the Control Table with Read Instruction Packets. WRITE Instruction Packets enable users to control the device by changing specific Data in the Control Table. The Address is a unique value when accessing a specific Data in the Control Table with Instruction Packets. In order to read or write data, users must designate a specific Address in the Instruction Packet. Please refer to Protocol 2.0 for more details about Instruction Packets.

NOTE : Two' s complement is applied for the negative value. For more information, please refer to Two' s complement from Wikipedia.

Area (EEPROM, RAM)

The Control Table is divided into 2 Areas. Data in the RAM Area is reset to initial values when the power is reset(Volatile). On the other hand, data in the EEPROM Area is maintained even when the device is powered off(Non-Volatile).

Data in the EEPROM Area can only be written to if Torque Enable(64) is cleared to '0' (Off).

Size

The Size of data varies from 1 ~ 4 bytes depend on their usage. Please check the size of data when updating the data with an Instruction Packet. For data larger than 2 bytes will be saved according to Little Endian.

Access

The Control Table has two different access properties. 'RW' property stands for read and write access permission while 'R' stands for read only access permission. Data with the read only property cannot be changed by the WRITE Instruction. Read only property('R') is generally used for measuring and monitoring purpose, and read write property('RW') is used for controlling device.

Initial Value

Each data in the Control Table is restored to initial values when the device is turned on. Default values in the EEPROM area are initial values of the device (factory default settings). If any values in the EEPROM area are modified by a user, modified values will be restored as initial values when the device is turned on. Initial Values in the RAM area are restored when the device is turned on.

Control Table of EEPROM Area

Address	Size (Byte)	Data Name	Access	Default Value	Range	Unit
0	2	Model Number	R	1,060	-	-
2	4	Model Information	R	-	-	-
6	1	Firmware Version	R	-	-	-
7	1	ID	RW	1	0 ~ 253	-
8	1	Baud Rate	RW	1	0 ~ 7	-

Address	Size (Byte)	Data Name	Access	Default Value	Range	Unit
9	1	Return Delay Time	RW	250	0 ~ 254	2 [μ sec]
10	1	Drive Mode	RW	0	0 ~ 1	-
11	1	Operating Mode	RW	3	0 ~ 16	-
12	1	Secondary(Shadow) ID	RW	255	0 ~ 252	-
13	1	Protocol Type	RW	2	1 ~ 2	-
20	4	Homing Offset	RW	0	-1,044,479 ~ 1,044,479	1 [pulse]
24	4	Moving Threshold	RW	10	0 ~ 1,023	0.229 [rev/min]
31	1	Temperature Limit	RW	72	0 ~ 100	1 [° C]
32	2	Max Voltage Limit	RW	140	60 ~ 140	0.1 [V]
34	2	Min Voltage Limit	RW	60	60 ~ 140	0.1 [V]
36	2	PWM Limit	RW	885	0 ~ 885	0.113 [%]
44	4	Velocity Limit	RW	265	0 ~ 1,023	0.229 [rev/min]
48	4	Max Position Limit	RW	4,095	0 ~ 4,095	1 [pulse]
52	4	Min Position Limit	RW	0	0 ~ 4,095	1 [pulse]
63	1	Shutdown	RW	52	-	-

Control Table of RAM Area

Address	Size (Byte)	Data Name	Access	Default Value	Range	Unit
64	1	Torque Enable	RW	0	0 ~ 1	-
65	1	LED	RW	0	0 ~ 1	-
68	1	Status Return Level	RW	2	0 ~ 2	-
69	1	Registered Instruction	R	0	0 ~ 1	-
70	1	Hardware Error	R	0	-	-

Address	Size (Byte)	Data Name	Access	Default Value	Range	Unit
		Status				
76	2	Velocity I Gain	RW	1,000	0 ~ 16,383	-
78	2	Velocity P Gain	RW	100	0 ~ 16,383	-
80	2	Position D Gain	RW	4,000	0 ~ 16,383	-
82	2	Position I Gain	RW	0	0 ~ 16,383	-
84	2	Position P Gain	RW	640	0 ~ 16,383	-
88	2	Feedforward 2nd Gain	RW	0	0 ~ 16,383	-
90	2	Feedforward 1st Gain	RW	0	0 ~ 16,383	-
98	1	Bus Watchdog	RW	0	1 ~ 127	20 [msec]
100	2	Goal PWM	RW	-	-PWM Limit(36) ~ PWM Limit(36)	-
104	4	Goal Velocity	RW	-	-Velocity Limit(44) ~ Velocity Limit(44)	0.229 [rev/min]
108	4	Profile Acceleration	RW	0	0 ~ 32,767 0 ~ 32,737	214.577 [rev/min ²] 1 [ms]
112	4	Profile Velocity	RW	0	0 ~ 32,767	0.229 [rev/min]
116	4	Goal Position	RW	-	Min Position Limit(52) ~ Max Position Limit(48)	1 [pulse]
120	2	Realtime Tick	R	-	0 ~ 32,767	1 [msec]
122	1	Moving	R	0	0 ~ 1	-
123	1	Moving Status	R	0	-	-
124	2	Present PWM	R	-	-	-

Address	Size (Byte)	Data Name	Access	Default Value	Range	Unit
126	2	Present Load	R	-	-1,000 ~ 1,000	0.1 [%]
128	4	Present Velocity	R	-	-	0.229 [rev/min]
132	4	Present Position	R	-	-	1 [pulse]
136	4	Velocity Trajectory	R	-	-	0.229 [rev/min]
140	4	Position Trajectory	R	-	-	1 [pulse]
144	2	Present Input Voltage	R	-	-	0.1 [V]
146	1	Present Temperature	R	-	-	1 [° C]
168	2	Indirect Address 1	RW	224	64 ~ 661	-
170	2	Indirect Address 2	RW	225	64 ~ 661	-
172	2	Indirect Address 3	RW	226	64 ~ 661	-
...	-	-
218	2	Indirect Address 26	RW	249	64 ~ 661	-
220	2	Indirect Address 27	RW	250	64 ~ 661	-
222	2	Indirect Address 28	RW	251	64 ~ 661	-
224	1	Indirect Data 1	RW	0	0 ~ 255	-
225	1	Indirect Data 2	RW	0	0 ~ 255	-
226	1	Indirect Data 3	RW	0	0 ~ 255	-
...	-	-
249	1	Indirect Data 26	RW	0	0 ~ 255	-
250	1	Indirect Data 27	RW	0	0 ~ 255	-

Address	Size (Byte)	Data Name	Access	Default Value	Range	Unit
251	1	Indirect Data 28	RW	0	0 ~ 255	-
578	2	Indirect Address 29	RW	634	64 ~ 661	-
580	2	Indirect Address 30	RW	635	64 ~ 661	-
582	2	Indirect Address 31	RW	636	64 ~ 661	-
...	-	-
628	2	Indirect Address 54	RW	659	64 ~ 661	-
630	2	Indirect Address 55	RW	660	64 ~ 661	-
632	2	Indirect Address 56	RW	661	64 ~ 661	-
634	1	Indirect Data 29	RW	0	0 ~ 255	-
635	1	Indirect Data 30	RW	0	0 ~ 255	-
636	1	Indirect Data 31	RW	0	0 ~ 255	-
...	-	-
659	1	Indirect Data 54	RW	0	0 ~ 255	-
660	1	Indirect Data 55	RW	0	0 ~ 255	-
661	1	Indirect Data 56	RW	0	0 ~ 255	-

CAUTION : Protocol 1.0 does not support addresses greater than 256. Therefore, Indirect Address 29 ~ 56 and Indirect Data 29 ~ 56 can only be accessed with Protocol 2.0.

Control Table Description

CAUTION : Data in the EEPROM Area can only be written when the value of Torque Enable(64) is cleared to '0' .

Model Number(0)

This address stores model number of DYNAMIXEL.

Firmware Version(6)

This address stores firmware version of DYNAMIXEL.

ID(7)

地址：北京市亦庄经济开发区凉水河二街8号大族企业湾7号楼A座2层 邮编：100176
 网址：www.bjrobot.com 邮箱：znj@bjrobot.com 全国服务热线：400 099 1872

The ID is a unique value in the network to identify each DYNAMIXEL with an Instruction Packet. 0~252 (0xFC) values can be used as an ID, and 254(0xFE) is occupied as a broadcast ID. The Broadcast ID(254, 0xFE) can send an Instruction Packet to all connected DYNAMIXEL simultaneously.

NOTE : Please avoid using an identical ID for multiple DYNAMIXEL. You may face communication failure or may not be able to detect DYNAMIXEL with an identical ID.

Baud Rate(8)

Baud Rate determines serial communication speed between a controller and DYNAMIXEL.

Value	Baud Rate	Margin of Error
7	4.5M	0.000%
6	4M	0.000%
5	3M	0.000%
4	2M	0.000%
3	1M	0.000%
2	115,200	0.000%
1(Default)	57,600	0.000%
0	9,600	0.000%

NOTE : Less than 3% of the baud rate error margin will not affect to UART communication.

NOTE : For the stable communication with higher Baudrate, configure USB Latency value to the lower.

USB Latency Setting

Return Delay Time(9)

After the DYNAMIXEL receives an Instruction Packet, it delays transmitting the Status Packet for Return Delay Time(9). For instance, if the Return Delay Time(9) is set to '10', the Status Packet will be returned after 20[μ sec] when the Instruction Packet is received.

Unit	Value Range	Description
2[μ sec]	0 ~ 254	Default value '250' (500[μ sec]), Maximum 508[μ sec]

Drive Mode(10)

This address configures Drive Mode of DYNAMIXEL.

Bit	Item	Description
Bit 7(0x80)	-	Unused, always '0'
Bit 6(0x40)	-	Unused, always '0'

Bit	Item	Description
Bit 5(0x20)	-	Unused, always '0'
Bit 4(0x10)	-	Unused, always '0'
Bit 3(0x08)	-	Unused, always '0'
Bit 2(0x04)	Profile Configuration	[0] Velocity-based Profile: Create a Profile based on Velocity [1] Time-based Profile: Create Profile based on time ※ Please refer to Profile Velocity(112)
Bit 1(0x02)	-	Unused, always '0'
Bit 0(0x01)	Normal/Reverse Mode	[0] Normal Mode: CCW(Positive), CW(Negative) [1] Reverse Mode: CCW(Negative), CW(Positive)

NOTE : Time-based Profile is available from firmware V42.

NOTE : If the value of Bit 0(Normal/Reverse Mode) of the Drive Mode(10) is set to 1, rotational direction is inverted.

Thus, Goal Position, Present Position will have a inverted direction.

This feature can be very useful when configuring symmetrical joint or wheel system.

Operating Mode(11)

Value	Operating Mode	Description
1	Velocity Control Mode (0° ~ 360°)	This mode controls velocity and ideal for wheel operation. This mode is identical to the Wheel Mode(endless) from existing DYNAMIXEL.
3(Default)	Position Control Mode	This mode controls position and identical to the Joint Mode. Operating position range is limited by Max Position Limit(48) and Min Position Limit(52). This mode is ideal for articulated robots that each joint rotates less than 360° .
4	Extended Position Control Mode (Multi-turn)	This mode controls position and identical to Multi-turn Mode. 512 turns are supported(-256[rev] ~ 256[rev]) and ideal for multi-turn wrists or conveyer systems or a system that requires an additional reduction gear.
16	PWM Control	This mode directly controls PWM output (Voltage Control

Value	Operating Mode	Description
	Mode (Voltage Control Mode)	Mode)

NOTE : Switching Operating Mode will reset gains(PID, Feedforward) properly to the selected Operating Mode. The profile generator and limits will also be reset.

Profile Velocity(112), Profile Acceleration(108) : Reset to '0'

Goal PWM(100) : Reset to PWM Limit(36)

NOTE : PWM is the abbreviation for Pulse Width Modulation that modulates PWM Duty to control motors.

It changes pulse width to control average supply voltage to the motor and this technique is widely used in the motor control field.

PWM Control Mode is similar to the Wheel Mode of DYNAMIXEL AX and RX series.

Use Goal PWM(100) on PWM Control Mode in order to control supply voltage for DYNAMIXEL.

NOTE : Present Position(132) represents 4 byte continuous range from -2,147,483,648 to 2,147,483,647 when Torque is turned off regardless of Operating Mode(11).

However, Present Position(132) will be reset to an absolute position value of one full rotation in those cases:

When Operating Mode(11) is changed to Position Control Mode, Present Position(132) will be reset to an absolute position value of a full rotation.

When torque is turned on in Position Control Mode, Present Position(132) will be reset to an absolute position value of one full rotation.

When turning off the power supply on Extended Position Control Mode, Present Position(132) will be reset to an absolute position value of one full rotation.

Present Position(132) value can be affected by Homing Offset(20).

Secondary(Shadow) ID(12)

Set the DYNAMIXEL's Secondary ID. Secondary ID(12) is a value to identify each DYNAMIXEL, just like the ID(7). However, unlike ID(7), Secondary ID(12) is not a unique value. Therefore, DYNAMIXEL with the same Secondary ID value form a group. The differences between Secondary ID(12) and ID(7) are as follows :

Secondary ID(12) is not a unique value. i.e., a lot of DYNAMIXEL may have the same Secondary ID value.

ID(7) has a higher priority than Secondary ID(12). i.e., if Secondary ID(12) and ID(7) are the same, ID(7) will be applied first.

The EEPROM area of the Control Table cannot be modified with Secondary ID(12). Only the RAM area can be modified.

If Instruction Packet ID is the same as Secondary ID(12), the Status Packet will not be returned.

If the value of Secondary ID(12) is 253 or higher, the Secondary ID function is deactivated.

Values	Description
0 ~ 252	Activate Secondary ID function

Values	Description
253 ~ 255	Deactivate Secondary ID function, Default value '255'

The following are examples of operation when there are five DYNAMIXEL with ID (7) set from 1 to 5.

Set all five DYNAMIXEL' Secondary ID(12) to '5' .

Send Write Instruction Packet(ID = 1, LED(65) = 1).

Turn on LED of DYNAMIXEL with ID '1' and return the Status Packet.

Send Write Instruction Packet(ID = 5, LED(65) = 1).

Turn on LED on five DYNAMIXEL. However, Status Packet of DYNAMIXEL with ID '5' will be returned.

Set the Secondary ID(12) of all five DYNAMIXEL to '100' .

Send Write Instruction Packet(ID = 100, LED(65) = 0).

Turn off LED on five DYNAMIXEL. However, as there is no DYNAMIXEL with ID '100' , Status Packet is not returned.

Protocol Type(13)

Users can select DYNAMIXEL protocol type (1.0 and 2.0).

Even if Protocol 1.0 is selected, Protocol 2.0 Control Table will be used.

It is recommended to use an identical protocol type for multiple DYNAMIXEL.

Value	Protocol Type	Compatible DYNAMIXEL
1	1.0	AX Series, DX Series, RX Series, EX Series, MX Series with Firmware below v39
2(default)	2.0	MX-28/64/106 with Firmware v39 or above, X Series, PRO Series

WARNING : In order to change the Protocol Type to Protocol 1.0, please use DYNAMIXEL Wizard 2.0 as R+ Manager 2.0 does not support Protocol 1.0.

NOTE : The protocol 2.0 is greatly enhanced from the protocol 1.0. Accessing some of the Control Table area might be denied if protocol 1.0 is selected. This manual complies with protocol 2.0. Please refer to the Protocol 1.0 and Protocol 2.0 of e-Manual for more details about the protocol.

NOTE : Please refer to the Protocol Compatibility table for product.

Homing Offset(20)

Users can adjust the Home position by setting Home Offset(20). The Homing Offset value is added to the Present Position(132).

Present Position(132) = Actual Position + Homing Offset(20)

Unit	Value Range	Description
about 0.088 [°]	-1,044,479 ~ 1,044,479 (-255 ~ 255[rev])	4,096 resolution

NOTE : In case of the Position Control Mode(Joint Mode) that rotates less than 360 degrees, any invalid Homing Offset(20) values will be ignored(valid range : -1,024 ~ 1,024).

NOTE : In the case of Reverse Mode bit is set in Drive Mode(10), the sign of Homing Offset value will not be reversed.

Moving Threshold(24)

This value helps to determine whether the DYNAMIXEL is in motion or not.

When the absolute value of Present Velocity(128) is greater than the Moving Threshold(24), Moving(122) is set to '1', otherwise it is cleared to '0'.

	Values	Description
Unit	about 0.229 rpm	All velocity related Data uses the same unit
Range	0 ~ 1,023	-

Temperature Limit(31)

This value limits operating temperature.

When the Present Temperature(146) that indicates internal temperature of DYNAMIXEL is greater than the Temperature Limit(31), the Over Heating Error Bit(0x04) and Hardware Error Bit(0x80) in the Hardware Error Status(70) will be set.

If Overheating Error Bit(0x04) is configured in the Shutdown(63), Torque Enable(64) is cleared to '0' and Torque will be disabled.

For more details, please refer to the Shutdown(63) section.

Unit	Value Range	Description
About 1°	0 ~ 100	0 ~ 100°

CAUTION : Do not set the temperature higher than the default value. When the temperature alarm shutdown occurs, wait 20 minutes to cool the temperature before re-use. Keep using the product when the temperature is high can cause severe damage.

Min/Max Voltage Limit(32, 34)

These values are maximum and minimum operating voltages. When current input voltage acquired from Present Input Voltage(144) exceeds the range of Max Voltage Limit(32) and Min Voltage Limit(34), Voltage Range Error Bit(0x01) and Hardware Error Bit(0x80) in the Hardware Error Status(70) are set. If Input Voltage Error Bit(0x10) is configured in the Shutdown(63), Torque Enable(64) is cleared to '0' and Torque is disabled. For more details, please refer to the Shutdown(63) section.

Unit	Value Range	Description
About 0.1V	60 ~ 140	6.0 ~ 14.0V

PWM Limit(36)

This value indicates maximum PWM output. Goal PWM(100) can't be configured with any values exceeding PWM Limit(36). PWM Limit(36) is commonly used in all operating mode as an output limit, therefore decreasing PWM output will result in decreasing torque and velocity. For more details, please refer to the Gain section of each operating modes.

Values	Description

Values	Description
0(0 [%]) ~ 885(100 [%])	885 = 100 [%] output

Velocity Limit(44)

This indicates the maximum value of Goal Velocity(104). For more details, please refer to Goal Velocity(104).

Unit	Value Range
0.229rpm	0 ~ 1,023

NOTE: The default value of Velocity Limit(44) has been decreased since Firmware V42.

Min/Max Position Limit(48, 52)

These values limit maximum and minimum target positions for Position Control Mode(Joint Mode) within the range of 1 rotation(0 ~ 4,095). Therefore, Goal Position(116) should be configured within the position limit range. These values are not used in Extended Position Control Mode.

Unit	Value Range
0.088°	0 ~ 4,095(1 rotation)

NOTE : Max Position Limit(48) and Min Position Limit(52) are only used in Position Control Mode with a single turn.

Shutdown(63)

The DYNAMIXEL can protect itself by detecting dangerous situations that could occur during the operation.

Each Bit is inclusively processed with the ‘OR’ logic, therefore, multiple options can be generated.

For instance, when ‘0x05’ (binary : 0000101) is defined in Shutdown(63), DYNAMIXEL can detect both Input Voltage Error(binary : 00000001) and Overheating Error(binary : 00000100).

If those errors are detected, Torque Enable(64) is cleared to ‘0’ and the motor output becomes 0 [%].

REBOOT is the only method to reset Torque Enable(64) to ‘1’ (Torque ON) after the shutdown.

Check Hardware Error Bit(0x80) in a error field of Status Packet or a present status via Hardware Error Status(70) The followings are detectable situations.

Bit	Item	Description
Bit 7	-	Unused, Always ‘0’
Bit 6	-	Unused, Always ‘0’
Bit 5	Overload Error(default)	Detect persistent load that exceeds maximum output
Bit	Electrical Shock	Detect electric shock on the circuit or insufficient power to

Bit	Item	Description
4	Error(default)	operate the motor
Bit 3	Motor Encoder Error	Detect malfunction of the motor encoder
Bit 2	OverHeating Error(default)	Detect internal temperature exceeds the configured operating temperature
Bit 1	-	Unused, Always '0'
Bit 0	Input Voltage Error	Detect input voltage exceeds the configured operating voltage

NOTE :

If Shutdown occurs, LED will flicker every second. (Firmware v41 or above)

If Shutdown occurs, reboot the device.

H/W REBOOT : Turn off and turn on the power again

S/W REBOOT : Transmit REBOOT Instruction (For more details, refer to the Reboot section of e-Manual.)

Torque Enable(64)

Controls Torque ON/OFF. Writing '1' to this address will turn on the Torque and all Data in the EEPROM area will be protected.

Value	Description
0(Default)	Turn off the torque
1	Turn on the torque and lock EEPROM area

NOTE : Present Position(132) can be reset when Operating Mode(11) and Torque Enable(64) are updated. For more details, please refer to the Homing Offset(20) and Present Position(132).

LED(65)

Turn on or turn off the LED on DYNAMIXEL.

Bit	Description
0(Default)	Turn OFF the LED
1	Turn ON the LED

NOTE : The LED indicates present status of the device.

Status	LED Representation
Booting	LED flickers once
Factory Reset	LED flickers 4 times

Status	LED Representation
Alarm	LED flickers
Boot Mode	LED On

Status Return Level(68)

This value decides how to return Status Packet when DYNAMIXEL receives an Instruction Packet.

Value	Responding Instructions	Description
0	PING Instruction	Status Packet will not be returned for all Instructions
1	PING Instruction READ Instruction	Status Packet will be returned only for READ Instruction
2	All Instructions	Status Packet will be returned for all Instructions

NOTE : If the ID of Instruction Packet is set to Broad Cast ID(0xFE), Status Packet will not be returned for READ and WRITE Instructions regardless of Status Return Level. For more details, please refer to the Status Packet section for Protocol 1.0 or Protocol 2.0.

Registered Instruction(69)

Value	Description
0	REG_WRITE instruction is not received
1	REG_WRITE instruction is received

NOTE : If ACTION instruction is executed, the value will be changed to 0.

Hardware Error Status(70)

This value indicates hardware error status. The DYNAMIXEL can protect itself by detecting dangerous situations that could occur during the operation.

Each Bit is inclusively processed with the ‘OR’ logic, therefore, multiple options can be generated.

For instance, when ‘0x05’ (binary : 0000101) is defined in Shutdown(63), DYNAMIXEL can detect both Input Voltage Error(binary : 0000001) and Overheating Error(binary : 0000100).

If those errors are detected, Torque Enable(64) is cleared to ‘0’ and the motor output becomes 0 [%].

REBOOT is the only method to reset Torque Enable(64) to ‘1’ (Torque ON) after the shutdown.

Check Hardware Error Bit(0x80) in a error field of Status Packet or a present status via Hardware Error Status(70) The followings are detectable situations.

Bit	Item	Description
Bit 7	-	Unused, Always ‘0’
Bit	-	Unused, Always ‘0’

Bit	Item	Description
6		
Bit 5	Overload Error(default)	Detect persistent load that exceeds maximum output
Bit 4	Electrical Shock Error(default)	Detect electric shock on the circuit or insufficient power to operate the motor
Bit 3	Motor Encoder Error	Detect malfunction of the motor encoder
Bit 2	OverHeating Error(default)	Detect internal temperature exceeds the configured operating temperature
Bit 1	-	Unused, Always '0'
Bit 0	Input Voltage Error	Detect input voltage exceeds the configured operating voltage

NOTE :

If Shutdown occurs, LED will flicker every second. (Firmware v41 or above)

If Shutdown occurs, reboot the device.

H/W REBOOT : Turn off and turn on the power again

S/W REBOOT : Transmit REBOOT Instruction (For more details, refer to the Reboot section of e-Manual.)

Velocity PI Gain(76, 78)

These values indicate Gains of Velocity Control Mode.

Gains of DYNAMIXEL 's internal controller can be calculated from Gains of the Control Table as shown below.

The constant in each equations include sampling time.

Velocity P Gain of DYNAMIXEL 's internal controller is abbreviated to KVP and that of the Control Table is abbreviated to KVP(TBL).

	Controller Gain	Conversion Equations	Range	Description
Velocity I Gain(76)	KVI	$KVI = KVI(TBL) / 65,536$	0 ~ 16,383	I Gain
Velocity P Gain(78)	KVP	$KVP = KVP(TBL) / 128$	0 ~ 16,383	P Gain

Below figure is a block diagram describing the velocity controller in Velocity Control Mode. When the instruction transmitted from the user is received by DYNAMIXEL, it takes following steps until driving the horn.

An Instruction from the user is transmitted via DYNAMIXEL bus, then registered to Goal Velocity(104).

Goal Velocity(104) is converted to desired velocity trajectory by Profile Acceleration(108).

The desired velocity trajectory is stored at Velocity Trajectory(136).
 PI controller calculates PWM output for the motor based on the desired velocity trajectory.
 Goal PWM(100) sets a limit on the calculated PWM output and decides the final PWM value.
 The final PWM value is applied to the motor through an Inverter, and the horn of DYNAMIXEL is driven.
 Results are stored at Present Position(132), Present Velocity(128), Present PWM(124) and Present Load(126).

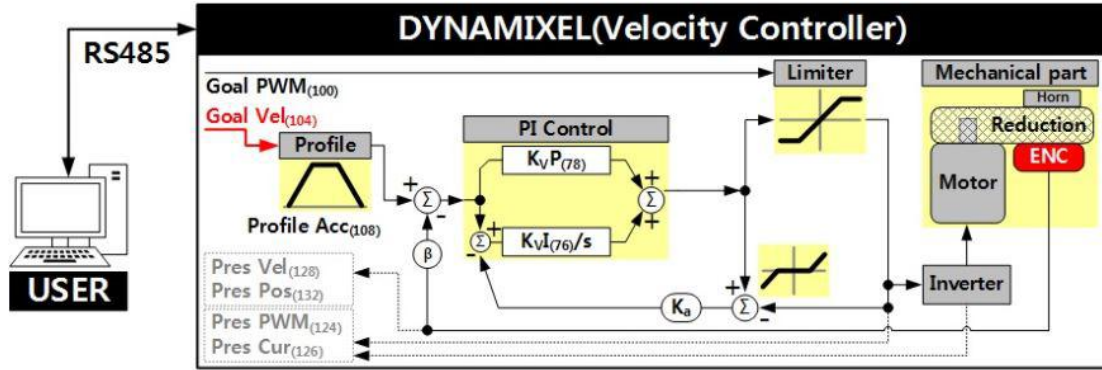

NOTE : K_a stands for Anti-windup Gain and β is a conversion coefficient of position and velocity that cannot be modified by users. For more details about the PID controller, please refer to the PID Controller at wikipedia.

Position PID Gain(80, 82, 84), Feedforward 1st/2nd Gains(88, 90)

These Gains are used in Position Control Mode and Extended Position Control Mode. Gains of DYNAMIXEL's internal controller can be calculated from Gains of the Control Table as shown below. The constant in each equations include sampling time. Position P Gain of DYNAMIXEL's internal controller is abbreviated to K_{PP} and that of the Control Table is abbreviated to $K_{PP}(TBL)$.

	Controller Gain	Conversion Equations	Range	Description
Position D Gain(80)	K_{PD}	$K_{PD} = K_{PD}(TBL) / 16$	0 ~ 16,383	D Gain
Position I Gain(82)	K_{PI}	$K_{PI} = K_{PI}(TBL) / 65,536$	0 ~ 16,383	I Gain
Position P Gain(84)	K_{PP}	$K_{PP} = K_{PP}(TBL) / 128$	0 ~ 16,383	P Gain
Feedforward 2nd Gain(88)	K_{FF2nd}	$K_{FF2nd}(TBL) / 4$	0 ~ 16,383	Feedforward Acceleration Gain
Feedforward 1st Gain(90)	K_{FF1st}	$K_{FF1st}(TBL) / 4$	0 ~ 16,383	Feedforward Velocity Gain

Below figure is a block diagram describing the position controller in Position Control Mode and Extended Position Control Mode. When the instruction from the user is received by DYNAMIXEL, it takes following steps until driving the horn.

An Instruction from the user is transmitted via DYNAMIXEL bus, then registered to Goal Position(116).

Goal Position(116) is converted to desired position trajectory and desired velocity trajectory by Profile Velocity(112) and Profile Acceleration(108).

The desired position trajectory and desired velocity trajectory is stored at Position Trajectory(140) and Velocity Trajectory(136) respectively.

Feedforward and PID controller calculate PWM output for the motor based on desired trajectories. Goal PWM(100) sets a limit on the calculated PWM output and decides the final PWM value.

The final PWM value is applied to the motor through an Inverter, and the horn of DYNAMIXEL is driven.

Results are stored at Present Position(132), Present Velocity(128), Present PWM(124) and Present Load(126).

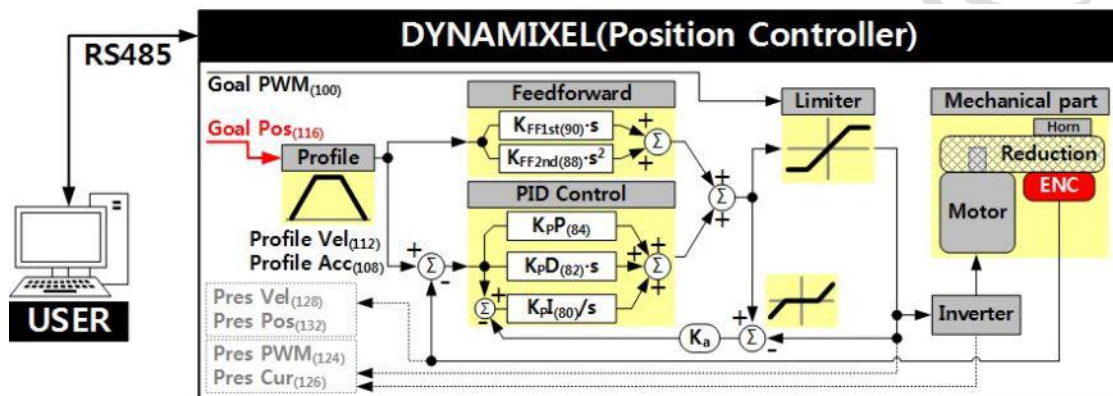

NOTE : In case of PWM Control Mode, both PID controller and Feedforward controller are deactivated while Goal PWM(100) value is directly controlling the motor through an Inverter. In this manner, users can directly control the supplying voltage to the motor.

NOTE : Ka is an Anti-windup Gain that cannot be modified by users.

For more details about the PID controller and Feedforward controller, please refer to the PID Controller and Feed Forward.

Bus Watchdog(98)

Bus Watchdog (98) is available from firmware v38. It is a safety device (Fail-safe) that stops the DYNAMIXEL if the communication between the controller and DYNAMIXEL communication (RS485, TTL) is disconnected due to an unspecified error. Communication is defined as all the Instruction Packet in the DYNAMIXEL Protocol.

	Values	Description
Unit	20[ms]	-
Range	0	Deactivate Bus Watchdog Function, Clear Bus Watchdog Error
Range	1 ~ 127	Activate Bus Watchdog
Range	-1	Bus Watchdog Error Status

The Bus Watchdog function monitors the communication interval (time) between the controller and DYNAMIXEL when Torque Enable(64) is '1'. If the measured communication interval

(time) is larger than Bus Watchdog(98), the DYNAMIXEL will stop. Bus Watchdog(98) will be changed to ‘-1’ (Bus Watchdog Error). If the Bus Watchdog Error screen appears, the Goal Value (Goal PWM(100), Goal Velocity(104), Goal Position(116)) will be changed to read-only-access. Therefore, when a new value is written to the Goal Value, a Range Error will be returned via the Status packet. If the value of Bus Watchdog(98) is changed to ‘0’, Bus Watchdog Error will be cleared.

NOTE : For details of Range Error, please refer to the protocol of the e-Manual.

The following are examples of the operation of the Bus Watchdog function.

After setting the Operating Mode(11) to speed control mode, change the Torque Enable(64) to ‘1’ .

If ‘50’ is written in the Goal Velocity(104), the DYNAMIXEL will rotate in CCW direction.

Change the value of Bus Watchdog(98) to ‘100’ (2,000 [ms]). (Activate Bus Watchdog Function)

If no instruction packet is received for 2,000 [ms], the DYNAMIXEL will stop. When it stops, the Profile Acceleration(108) and Profile Velocity(112) are applied as ‘0’ .

The value of Bus Watchdog(98) changes to ‘-1’ (Bus Watchdog Error). At this time, the access to the Goal Value will be changed to read-only.

If ‘150’ is written to the Goal Velocity(104), Range Error will be returned via Status Packet.

If the value of Bus Watchdog(98) is changed to ‘0’ , Bus Watchdog Error will be cleared.

If “150” is written in the Goal Velocity(104), the DYNAMIXEL will rotate in CCW direction.

Goal PWM(100)

In case of PWM Control Mode, both PID controller and Feedforward controller are deactivated while Goal PWM(100) value is directly controlling the motor through an Inverter. In other control modes, this value is used to limit PWM value. This value cannot exceed PWM Limit(36). Please refer to the Gain section in order to see how Goal PWM(100) affects to different control modes.

Range	Description
-PWM Limit(36) ~ PWM Limit(36)	Initial Value of PWM Limit(36) : ‘885’

Goal Velocity(104)

In case of Velocity Control Mode, Goal Velocity(104) can be used to set a desired velocity. This value cannot exceed Velocity Limit(44). For now, Goal Velocity(104) is used for desired velocity, but this value is not used to limit the velocity.

Unit	Value Range
0.229 rpm	-Velocity Limit(44) ~ Velocity Limit(44)

NOTE : The maximum velocity and maximum torque of DYNAMIXEL is affected by supplying voltage.

Therefore, if supplying voltage changes, so does the maximum velocity. This manual complies with recommended supply voltage(12[V]).

NOTE : If Profile Acceleration(108) and Goal Velocity(104) are modified simultaneously, modified Profile Acceleration(108) will be used to process Goal Velocity(104).

Profile Acceleration(108)

If Velocity-based Profile is selected for Drive Mode(10), Profile Acceleration(108) sets

acceleration of the Profile.

If Time-based Profile is selected for Drive Mode(10), Profile Acceleration(108) sets accelerating time of the Profile.

Profile Acceleration(108) is applied in all control mode except Current Control Mode.

Please refer to Profile Velocity(112) for more details.

Velocity-based Profile	Values	Description
Unit	214.577 [rev/min ²]	Sets acceleration of the Profile
Range	0 ~ 32767	'0' stands for an infinite acceleration

Time-based Profile	Values	Description
Unit	1 [msec]	Sets accelerating time of the Profile
Range	0 ~ 32737	'0' stands for an infinite accelerating time('0 [msec]'). Profile Acceleration(108) will not exceed 50% of Profile Velocity(112) value.

NOTE : Time-based Profile is available from the firmware version 42.

Profile Velocity(112)

If Velocity-based Profile is selected for Drive Mode(10), Profile Velocity(112) sets the maximum velocity of the Profile.

If Time-based Profile is selected for Drive Mode(10), Profile Velocity(112) sets the time span for the Profile.

Profile Velocity(112) is applied only in Position Control Mode and Extended Position Control Mode.

NOTE: Velocity Control Mode only uses Profile Acceleration(108) without Profile Velocity(112).

Velocity-based Profile	Values	Description
Unit	0.229 [rev/min]	Sets velocity of the Profile
Range	0 ~ 32767	'0' stands for an infinite velocity

Time-based Profile	Values	Description
Unit	1 [msec]	Sets the time span for the Profile
Range	0 ~ 32737	'0' stands for an infinite velocity. Profile Acceleration(108) will not exceed 50% of Profile Velocity(112) value.

NOTE : Time-based Profile is available from the firmware V42.

The Profile is an acceleration/deceleration control method to reduce vibration, noise and load of the motor by controlling dramatically changing velocity and acceleration.

It is also called Velocity Profile as it controls acceleration and deceleration based on velocity.

DYNAMIXEL provides 3 different types of Profile. The following explains 3 Profiles.

Profiles are usually selected by the combination of Profile Velocity(112) and Profile Acceleration(108).

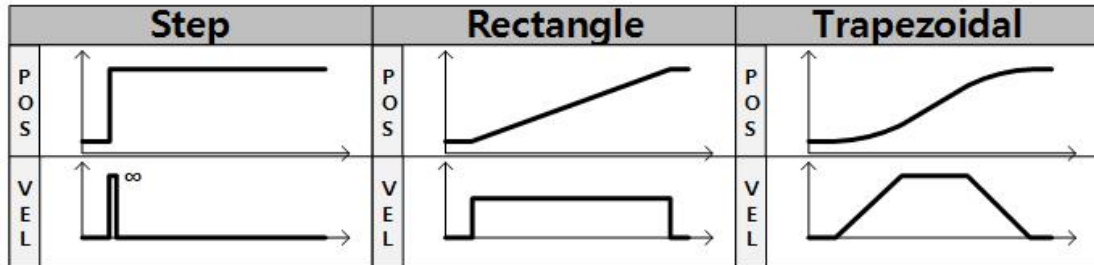

When given Goal Position(116), DYNAMIXEL's profile creates desired velocity trajectory based on present velocity(initial velocity of the Profile).

When DYNAMIXEL receives updated desired position from a new Goal Position(116) while it is moving toward the previous Goal Position(116), velocity smoothly varies for the new desired velocity trajectory.

Maintaining velocity continuity while updating desired velocity trajectory is called Velocity Override.

For a simple calculation, let's assume that the initial velocity of the Profile is '0'.

The following explains how Profile processes Goal Position(116) instruction in Position Control mode, Extended Position Control Mode.

An Instruction from the user is transmitted via DYNAMIXEL bus, then registered to Goal Position(116) (If Velocity-based Profile is selected).

Acceleration time(t1) is calculated from Profile Velocity(112) and Profile Acceleration(108).

Types of Profile is decided based on Profile Velocity(112), Profile Acceleration(108) and total travel distance(Δ Pos, the distance difference between desired position and present position).

Selected Profile type is stored at Moving Status(123).

DYNAMIXEL is driven by the calculated desired trajectory from Profile.

desired velocity trajectory and desired position trajectory from Profile are stored at Velocity Trajectory(136) and Position Trajectory(140) respectively.

Condition	Types of Profile
VPRFL(112) = 0	Profile not used (Step Instruction)
(VPRFL(112) ≠ 0) & (APRF(108) = 0)	Rectangular Profile
(VPRFL(112) ≠ 0) & (APRF(108) ≠ 0)	Trapezoidal Profile

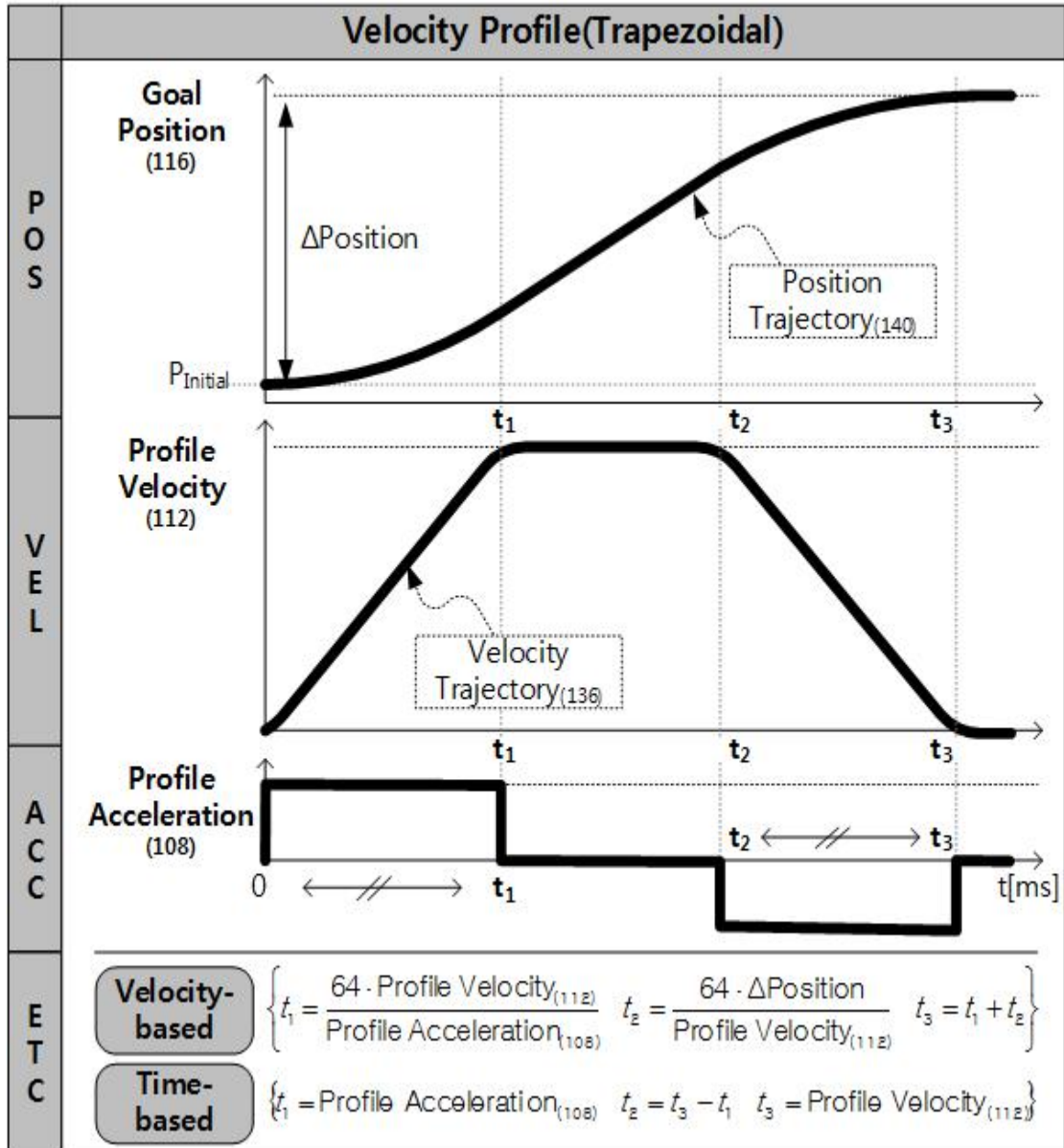

NOTE : Velocity Control Mode only uses Profile Acceleration(108). Step and Trapezoidal Profiles are supported. Velocity Override are supported as well. Acceleration time(t1) can be calculated as below equation.

Velocity-based Profile : $t_1 = 64 * \{ \text{Goal Velocity}(104) / \text{Profile Acceleration}(108) \}$

Time-based Profile : $t_1 = \text{Profile Acceleration}(108)$

NOTE : If Time-based Profile is selected, Profile Velocity(112) is used to set the time span of the Profile(t3), while Profile Acceleration(108) sets accelerating time(t1) in millisecond[ms]. Profile Acceleration(108) will not exceed 50% of Profile Velocity(112) value.

Goal Position(116)

Desired position can be set with Goal Position(116). From the front view of DYNAMIXEL, CCW is an increasing direction whereas CW is a decreasing direction. The way to reaching Goal Position(116) is differ by 4 Profiles provided by DYNAMIXEL. Please refer to the Profile Velocity(112) for more details.

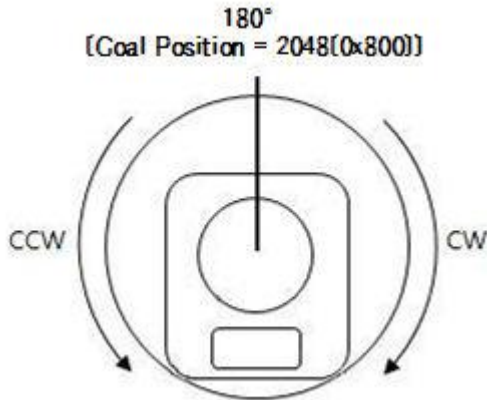

Mode	Values	Description
Position Control Mode	Min Position Limit(52) ~ Max Position Limit(48)	Initial Value : 0 ~ 4,095
Extended Position Control Mode	-1,048,575 ~ 1,048,575	-256[rev] ~ 256[rev]

Degree Conversion Constant	Description
0.088° /Value	1[rev] : 0 ~ 4,095

NOTE : Profile Velocity(112) and Profile Acceleration(108) are applied in below cases:

In Position Control Mode, Profile Velocity(112) and Profile Acceleration(108) are used to create a new profile when Goal Position(116) is updated.

In Velocity Control Mode, Profile Acceleration(108) is used to create a new profile when Goal Velocity(104) is updated.

NOTE : When turning off the power supply or changing Operation Mode on Extended Position Control Mode, the value of Present Position is reset to the absolute position value of single turn .

NOTE : Present Position(132) represents 4 byte continuous range from -2,147,483,648 to 2,147,483,647 when Torque is turned off regardless of Operating Mode(11).

However, Present Position(132) will be reset to an absolute position value of one full rotation in those cases:

When Operating Mode(11) is changed to Position Control Mode, Present Position(132) will be reset to an absolute position value of a full rotation.

When torque is turned on in Position Control Mode, Present Position(132) will be reset to an absolute position value of one full rotation.

When turning off the power supply on Extended Position Control Mode, Present Position(132) will be reset to an absolute position value of one full rotation.

Present Position(132) value can be affected by Homing Offset(20) .

Realtime Tick(120)

This value indicates DYNAMIXEL' s time.

Unit	Value Range	Description

Unit	Value Range	Description
1 ms	0 ~ 32,767	The value resets to '0' when it exceeds 32,767

Moving(122)

This value indicates whether DYNAMIXEL is in motion or not.

If absolute value of Present Velocity(128) is greater than Moving Threshold(24), Moving(122) is set to '1'.

Otherwise, it will be cleared to '0'.

However, this value will always be set to '1' regardless of Present Velocity(128) while Profile is in progress with Goal Position(116) instruction.

Value	Description
0	Movement is not detected
1	Movement is detected, or Profile is in progress(Goal Position(116) instruction is being processed)

Moving Status(123)

This one byte data provides additional information about the movement.

Following Error(0x08) and In-Position(0x01) are available under Position Control Mode, Extended Position Control Mode.

Bit	Value	Information	Description
Bit 7	X	-	Reserved
Bit 6	X	-	Reserved
Bit [5:4]	11 10 01 00	Velocity Profile	11 : Trapezoidal Profile 10 : Triangular Profile 01 : Rectangular Profile 00 : Profile not used(Step)
Bit 3	0 or 1	Following Error	DYNAMIXEL is following the desired position trajectory 0 : Following 1 : Not following
Bit 2	X	-	Reserved
Bit 1	0 or 1	Profile Ongoing	Profile is in progress with Goal Position(116) instruction 0 : Not in progress 1 : In progress
Bit 0	0 or 1	In-Position	DYNAMIXEL has arrived to the desired position 0 : Not arrived 1 : Arrived

NOTE : Triangular velocity profile is configured when Rectangular velocity profile cannot reach

地址：北京市亦庄经济开发区凉水河二街8号大族企业湾7号楼A座2层 邮编：100176

网址：www.bjrobot.com 邮箱：znj@bjrobot.com 全国服务热线：400 099 1872

to the Profile Velocity(112).

NOTE : In-Position bit will be set when the positional deviation is smaller than a predefined value under Position related control modes.

Present PWM(124)

This value indicates present PWM. For more details, please refer to the Goal PWM(100).

Present Load(126)

It means currently applied load. For example, the value is 512, it means the load is detected in the direction of CCW about 50% of the maximum torque.

Unit	Value Range	Description
0.1%	-1,000 ~ 1,000	Positive(CCW Load), Negative(CW Load)

NOTE : Present load is an inferred value based on the internal output value; not a measured value using torque sensor, etc. Therefore, it may be inaccurate for measuring weight or torque. It is recommended to use it for predicting the direction and size of the force being applied to the joint.

Present Velocity(128)

This value indicates present Velocity. For more details, please refer to the Goal Velocity(104).

Present Position(132)

This value indicates present Position. For more details, please refer to the Goal Position(116).

NOTE : Present Position(132) represents 4 byte continuous range from -2,147,483,648 to 2,147,483,647 when Torque is turned off regardless of Operating Mode(11).

However, Present Position(132) will be reset to an absolute position value of one full rotation in those cases:

When Operating Mode(11) is changed to Position Control Mode, Present Position(132) will be reset to an absolute position value of a full rotation.

When torque is turned on in Position Control Mode, Present Position(132) will be reset to an absolute position value of one full rotation.

When turning off the power supply on Extended Position Control Mode, Present Position(132) will be reset to an absolute position value of one full rotation.

Present Position(132) value can be affected by Homing Offset(20) .

Velocity Trajectory(136)

This is a target velocity trajectory created by Profile. Operating method can be changed based on control mode. For more details, please refer to the Profile Velocity(112).

Velocity Control Mode : When Profile reaches to the endpoint, Velocity Trajectory(136) becomes equal to Goal Velocity(104).

Position Control Mode, Extended Position Control Mode : Velocity Trajectory is used to create Position Trajectory(140). When Profile reaches to an endpoint, Velocity Trajectory(136) is cleared to '0' .

Position Trajectory(140)

This is a desired position trajectory created by Profile.

This value is only used in Position Control Mode, Extended Position Control Mode.

For more details, please refer to the Profile Velocity(112).

Present Input Voltage(144)

This value indicates present voltage that is being supplied. For more details, please refer to the Max/Min Voltage Limit(32, 34).

Present Temperature(146)

This value indicates internal temperature of DYNAMIXEL. For more details, please refer to the Temperature Limit(31).

Indirect Address, Indirect Data

Indirect Address and Indirect Data are useful when accessing two remote addresses in the Control Table as sequential addresses. Sequential addresses increase Instruction Packet efficiency. Addresses that can be defined as Indirect Address is limited to RAM area(Address 64 ~ 661). If specific address is allocated to Indirect Address, Indirect Address inherits features and properties of the Data from the specific Address. Property includes Size(Byte length), value range, and Access property(Read Only, Read/Write). For instance, allocating 65(Address of LED) to Indirect Address 1(168), Indirect Data 1(224) can perform exactly same as LED(65).

Example 1 Allocating Size 1 byte LED(65) to Indirect Data 1(224).

Indirect Address 1(168) : change the value to '65' which is the address of LED.

Set Indirect Data 1(224) to '1' : LED(65) also becomes '1' and LED is turned on.

Set Indirect Data 1(224) to '0' : LED(65) also becomes '0' and LED is turned off.

Example 2 Allocating Size 4 byte Goal Position(116) to Indirect Data 2(225), 4 sequential bytes have to be allocated.

Indirect Address 2(170) : change the value to '116' which is the first address of Goal Position.

Indirect Address 3(172) : change the value to '117' which is the second address of Goal Position.

Indirect Address 4(174) : change the value to '118' which is the third address of Goal Position.

Indirect Address 5(176) : change the value to '119' which is the fourth address of Goal Position.

Set 4 byte value '1,024' to Indirect Data 2 : Goal Position(116) also becomes '1024' and DYNAMIXEL moves.

Indirect Address Range	Description
64 ~ 661	EEPROM address can't be assigned to Indirect Address

NOTE : In order to allocate Data in the Control Table longer than 2[byte] to Indirect Address, all address must be allocated to Indirect Address like the above Example 2.

NOTE : Indirect Address 29 ~ 56 and Indirect Data 29 ~ 56 can only be accessed with Protocol 2.0.

How to Assemble

Wiring through Back Case

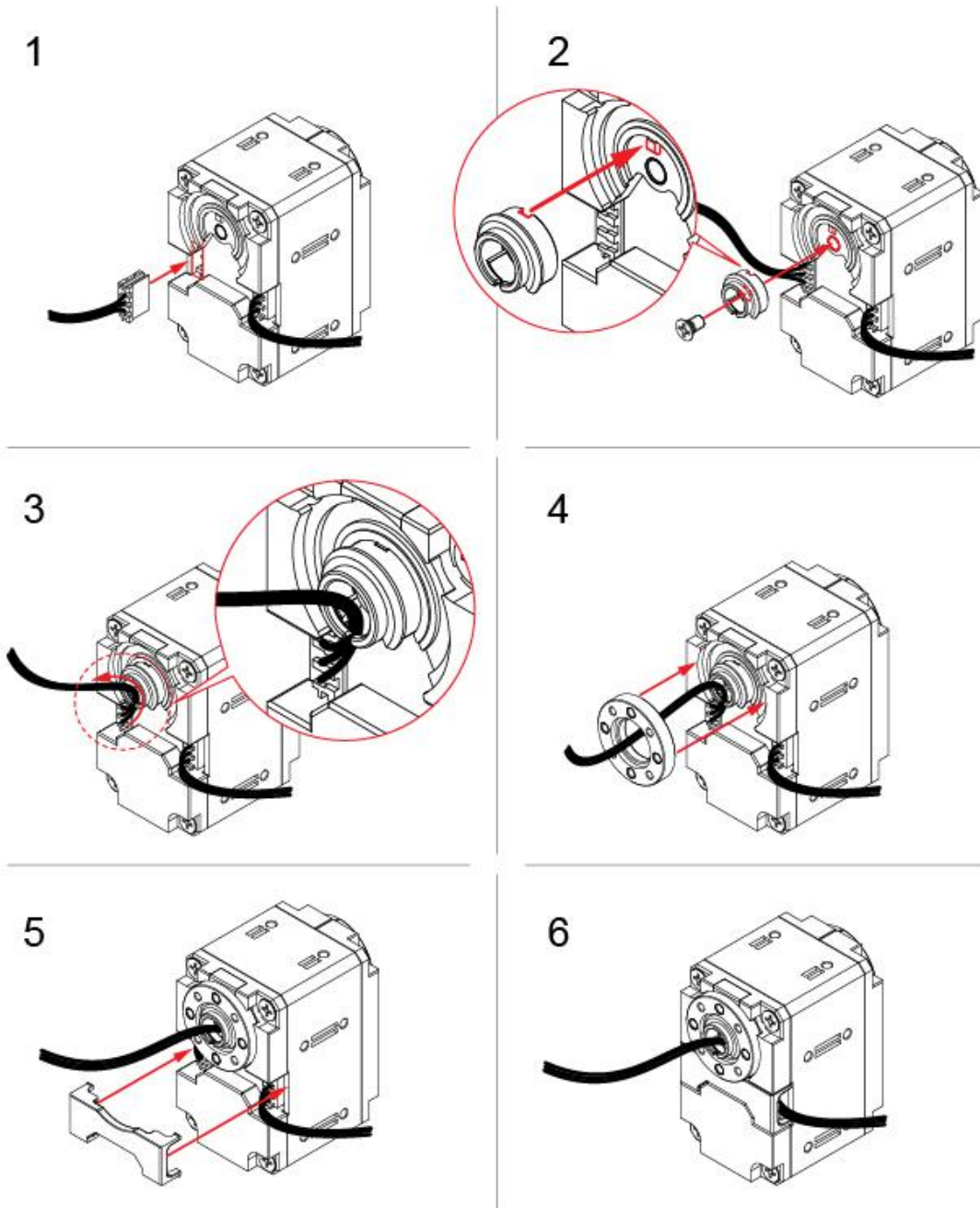

New XL430-W250 (Released on 2018 3rd quarter)

1

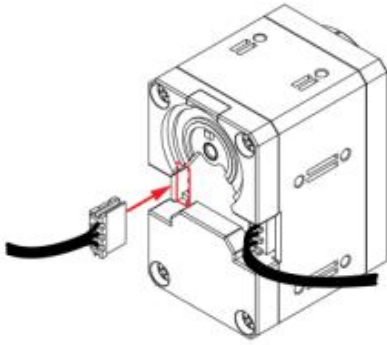

2

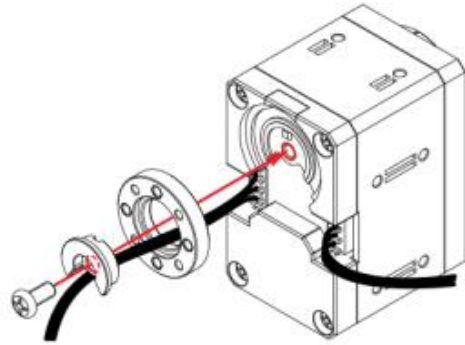

3

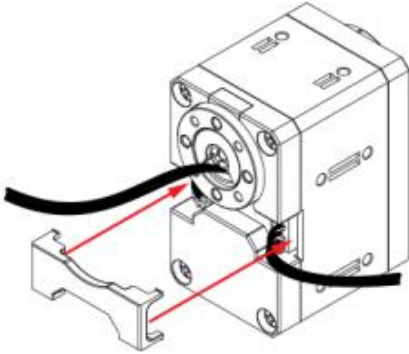

4

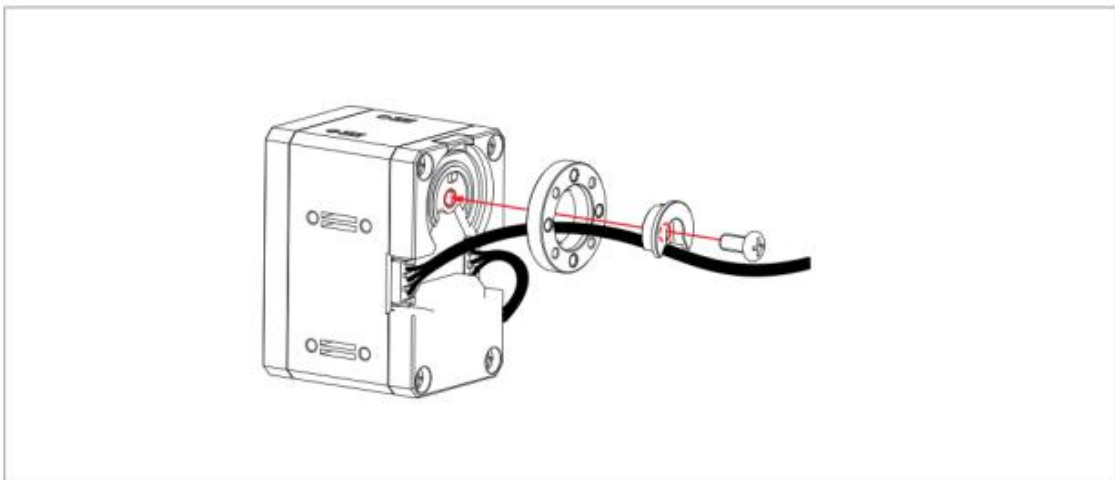
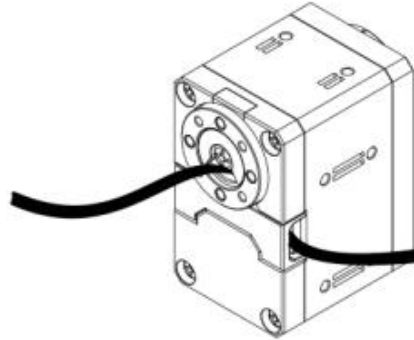

Old XL430-W250 (This type has been discontinued)

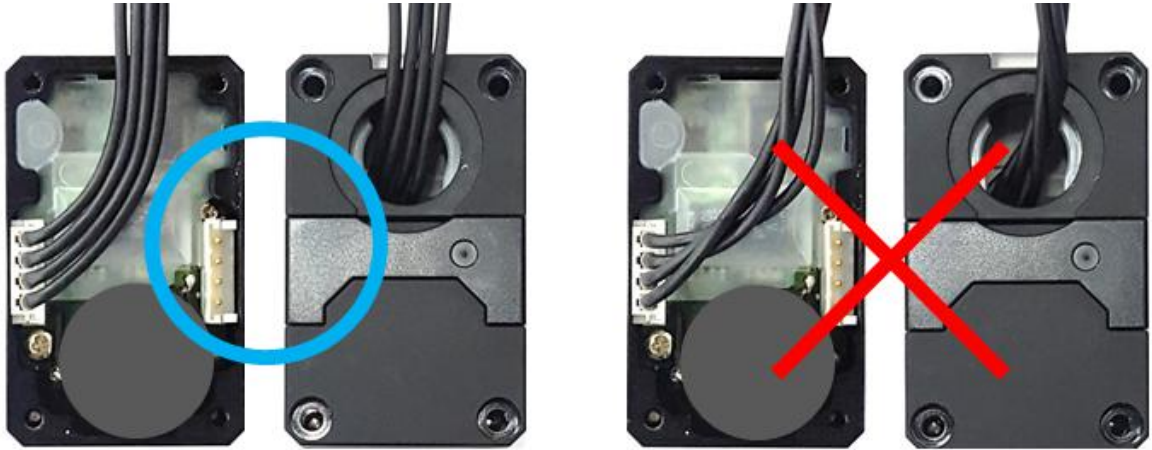

CAUTION : DYNAMIXEL-X series cable assembly through hollow case

Organize the entangled cable before assembling the back case.

Do not assemble the back case with entangled cable. The entangled cable can be squashed by the case and cause communication error.

Do not assemble both cables through the hollow case.

Option Frame Assembly

New XL430-W250

Option Frame Front A

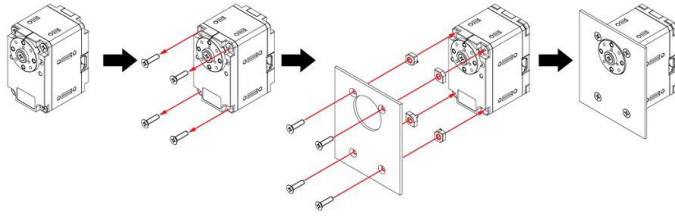

Option Frame Front B

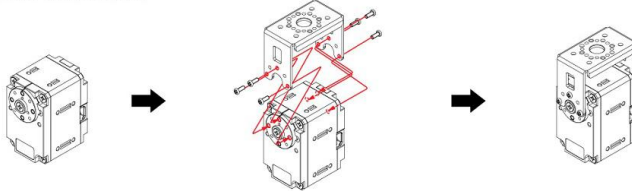

Option Frame Side A

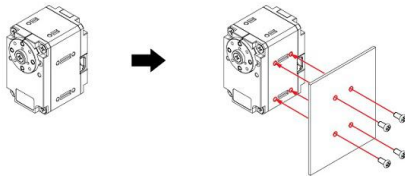

Option Frame Side B

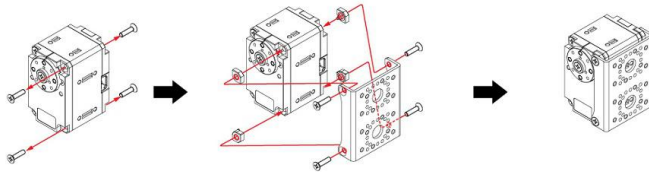

Option Frame Bottom A

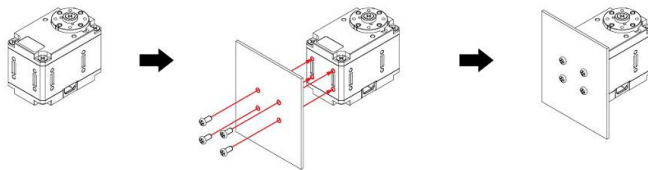

Option Frame Bottom B

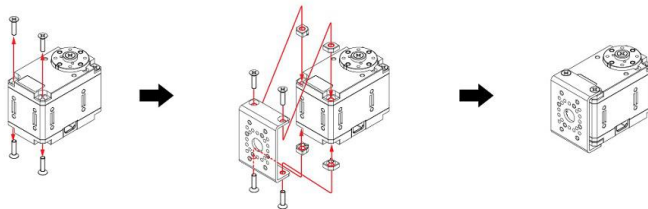
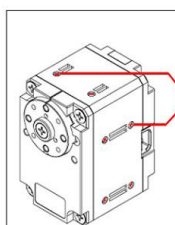
Side Tab

The maximum depth of the available side tab is 4mm. When tightening the bolts to a depth of more than 4mm, it may cause damage.

Taps on each side of the body are self-tapping holes. Be careful not to use of these holes repeatedly as it could damage the thread in the hole.



Old XL430-W250

智能佳机器人

Option Frame Front A

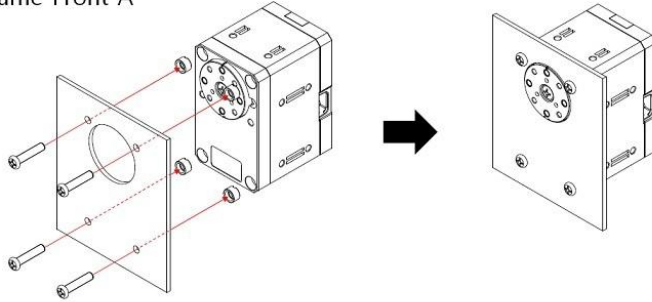

Option Frame Front B

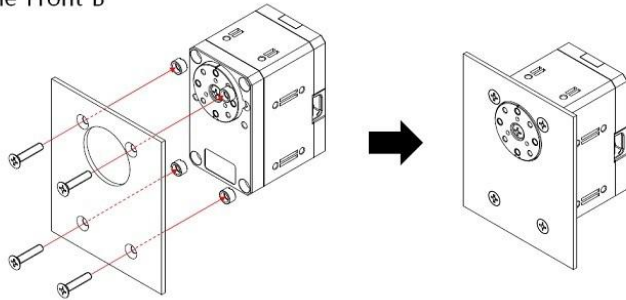

Option Frame Side 1

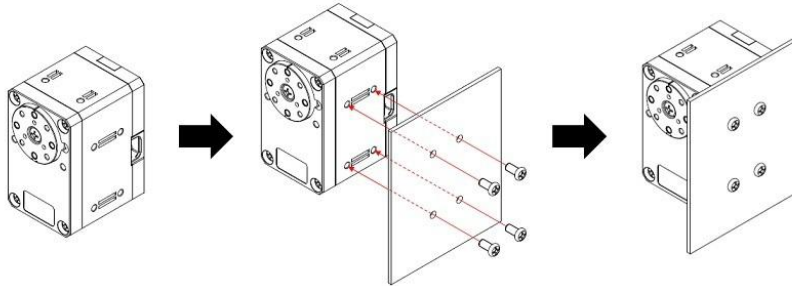

Option Frame Bottom 1

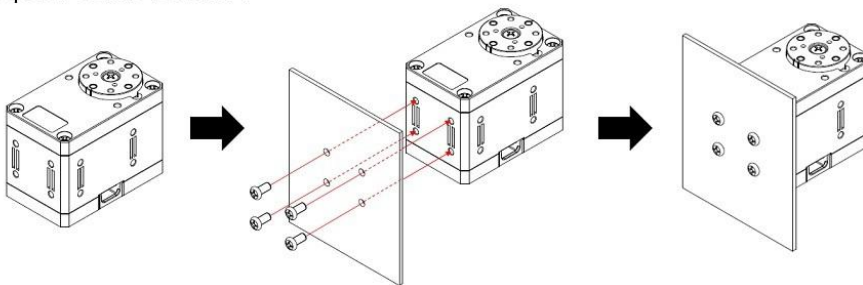

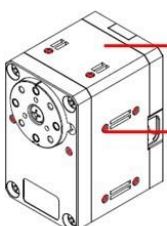

Side Tab

The maximum depth of the available side tab is 4mm. When tightening the bolts to a depth of more than 4mm, it may cause damage.

Taps on each side of the body are self-tapping holes. Be careful not to use of these holes repeatedly as it could damage the thread in the hole.



Reference

NOTE Compatibility Guide Harness Compatibility

Certifications

Please inquire us for information regarding unlisted certifications.

FCC

Note: This equipment has been tested and found to comply with the limits for a Class B digital device, pursuant to part 15 of the FCC Rules. These limits are designed to provide reasonable protection against harmful interference in a residential installation. This equipment generates, uses and can radiate radio frequency energy and, if not installed and used in accordance with the instructions, may cause harmful interference to radio communications. However, there is no guarantee that interference will not occur in a particular installation. If this equipment does cause harmful interference to radio or television reception, which can be determined by turning the equipment off and on, the user is encouraged to try to correct the interference by one more of the following measures:

Reorient or relocate the receiving antenna.

Increase the separation between the equipment and receiver.

Connect the equipment into an outlet on a circuit different from that to which the receiver is connected.

Consult the dealer or an experienced radio/TV technician for help.

WARNING

Any changes or modifications not expressly approved by the manufacturer could void the user's authority to operate the equipment.

Quick Start

Prerequisites

Power supply to DYNAMIXEL(12V SMPS / Controllers, compatible with DYNAMIXEL)

PC with Windows, Linux or MacOS.

Connection between PC and DYNAMIXEL (U2D2, USB2Dynamixel)

Compatible Software with DYNAMIXEL

WARNING:

USB2Dynamixel has been discontinued.

Some software may not support OS which you use. Be sure to read e-Manual of software you use to check the supported OS for right use of software.

NOTE:

U2D2 is a small size USB communication converter that enables to control and operate DYNAMIXEL with PC.

U2D2 Power Hub which combines with U2D2 supplies a variety external power source with a stable power supply to DYNAMIXEL.

Compatible Software with DYNAMIXEL

You can use exclusive software for DYNAMIXEL. See the software compatibility on the next table and choose a desired software for your project.

Model	AX Series	DX Series	RX Series	EX Series	MX Series	X-Series	PRO Series	P Series
-------	-----------	-----------	-----------	-----------	-----------	----------	------------	----------

Model	AX Series	DX Series	RX Series	EX Series	MX Series	X-Series	PRO Series	P Series
R+ Manager 2.0	X	X	X	X	O	O	O	O
DYNAMIXEL Wizard	O	X	X	O	O	X (XL320 can be used)	O	X
DYNAMIXEL Wizard 2.0	O	O	O	O	O	O	O	O
DYNAMIXEL SDK	O	O	O	O	O	O	O	O
DYNAMIXEL Workbench	O	O	O	O	O	O	O	O

NOTE: You can also use more variety of software. For more information, see the following to check software provided by ROBOTIS.

DYNAMIXEL to software Compatibility Table

Controller to software Compatibility Table

R+ Manager

R+ Manager is used to handle devices used by a robot. Major functions of this program are as follows.

Manage controller firmware. (Update and Restore)

Inspect the status of the controller and peripheral devices. (Test)

Set the required modes. (Settings)

NOTE: R+ Manager 2.0 or DYNAMIXEL Wizard 2.0 provides diverse features compared to R+ Manager.

R+ Manager 2.0

The R+ Manager 2.0 manages a controller and DYNAMIXEL devices that comprise the robot. By connecting the product, you can update the product to the latest version and test Control Table. The functions that were previously provided in RoboPlus Manager 1.0 and Wizard 1.0 have been combined in RoboPlus Manager 2.0.

WARNING: R+ Manager 2.0 is not compatible with DYNAMIXEL using protocol 1.0.

DYNAMIXEL Wizard 2.0 supports all DYNAMIXEL for Firmware Recovery, Firmware Update, and change data of Control Table of DYNAMIXEL.

DYNAMIXEL Wizard 2.0

DYNAMIXEL Wizard 2.0 is an optimized tool for managing DYNAMIXEL 's from various operating systems.

The following features are provided with DYNAMIXEL Wizard 2.0.

DYNAMIXEL Firmware Update

DYNAMIXEL Diagnosis

DYNAMIXEL Configuration and Test

DYNAMIXEL Data Plotting in Real-Time

地址：北京市亦庄经济开发区凉水河二街8号大族企业湾7号楼A座2层 邮编：100176

网址：www.bjrobot.com 邮箱：znj@bjrobot.com 全国服务热线：400 099 1872

Generate & Monitor DYNAMIXEL Packets

DYNAMIXEL SDK

DYNAMIXEL SDK is a software development kit that provides DYNAMIXEL control functions using packet communication. The API of DYNAMIXEL SDK is designed for DYNAMIXEL actuators and DYNAMIXEL-based platforms. You need to be familiar with C/C++ programming language for right use of the software. This e-Manual provides comprehensive information on ROBOTIS products and applications.

Supported Programming Languages and Features:

C, C++, C#, Python, Java, MATLAB, LabVIEW

Windows, Mac, Linux.

ROS

Arduino

DYNAMIXEL Workbench

DYNAMIXEL Workbench, based on DYNAMIXEL SDK, is library which provides simple and easier method to use DYNAMIXEL.

Supported Programming Languages and Features:

C++



Linux, MacOS

ROS

Arduino

NOTE: DYNAMIXEL Workbench may provide lack of contents or features compared to DYNAMIXEL SDK. In order to use DYNAMIXEL with sufficient contents, use DYNAMIXEL SDK.

Connector Information

Item	TTL
Pinout	1 GND 2 VDD 3 DATA
Diagram	
Housing	 JST EHR-03

Item	TTL
PCB Header	 <p>JST B3B-EH-A</p>
Crimp Terminal	JST SEH-001T-P0.6
Wire Gauge	21 AWG

WARNING: Check the pinout! The pinout of DYNAMIXEL can differ from the pinout of connector manufacturer.

Communication Circuit

To control the DYNAMIXEL actuators, the main controller needs to convert its UART signals to the half duplex type. The recommended circuit diagram for this is shown below.

TTL Communication

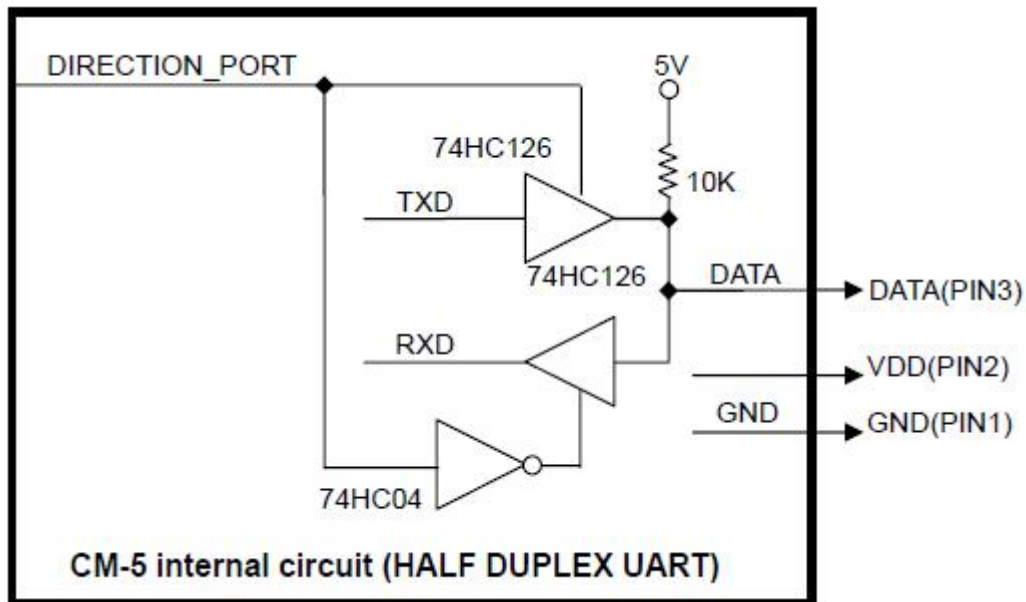

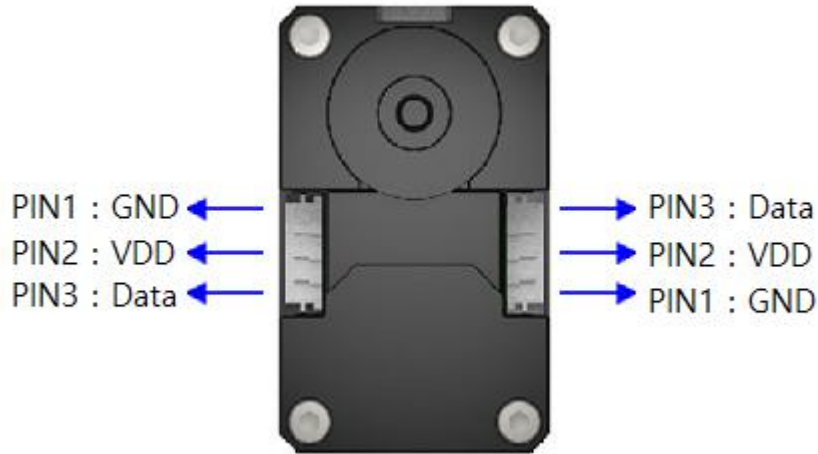

WARNING: Check the pinout! The pinout of DYNAMIXEL can differ from the pinout of connector manufacturer.